

**Product Specification for:
SAB-E-SSI_EMUL
SSI Emulator**



The SAB-E-R-SSI_EMUL module measures position of a Start/Stop or PWM sensor and uses this position information to emulate an MTS SSI transducer. The SAB-E-A-SSI_EMUL module measures a single analog voltage input and uses this information to emulate an MTS SSI transducer. Both modules respond to the SSI Clock signal with the scaled position data from the input device. In addition, a Remote Control Mode allows the SSI value to be controlled by a host device via the serial link.

Features

Model SAB-E-R

- Measures one channel of Start/Stop or PWM or Analog sensor with up to 5 micron resolution
- Software settable Gradient stored in EEPROM
- Green LED indicates sensor function

Model SAB-E-A

- Measures one channel of uni-polar or bipolar voltage input, +/- 10V or 0 to 10V
- 16 Bit A/D converter and multiple ranges for Analog input measurement
- Expanded input range to prevent saturation
- Software settable scale
- Instrumentation amplifier and precision reference for bridges etc..

All Models

- Outputs one channel of 24 or 25 bit SSI output
- SSI output is binary or Gray Code
- Fast output supports up to 500 KHZ clock speed
- Dip Switch programmable measurement resolution
- 24 or 25 bit mode programmable settable via Dip Switch
- Gray code or binary SSI output is settable via Dip Switch
- Remote control of SSI value possible
- Blinking Red LED indicates good operation of processor and SSI update rate
- Green LED indicates SSI activity
- Watchdog timer for reset upon software failure
- Convenient screw terminal connections

Specifications

Model SAB-E-R

- One channel of Start/Stop or PWM transducer measurement
- PWM Sensor can be free running (internally interrogated) and asynchronous to the converter
- Start/Stop measurement resolution is selectable via dip switch as 5, 10, 20, or 50 microns or .00025, .0005, .001 or .002 inches
- Default Gradient is 9.0 microsecond per inch
- 5 microsecond Hold Off period for Start/Stop sensors
- The SSI update rate can be as fast as 4 KHz
- Minimum time between SSI clock trains is 250 usec or sensor conversion time + 50 usec whichever is greater

Model SAB-E-A

- One channel of DC voltage input with differential or single ended input
- Jumper selectable input ranges: include +/- 10V 0 to 10V +/-5V and 0 to 5V
- Expanded input range is -10.25 to 10.25 VDC or 0 to 10.25V
- Optional input gain of up to 5000 with Instrumentation Amplifier
- 16 bit A/D converter provides 0.000153 volt resolution in Uni-polar mode or 0.00031 mv resolution in bipolar mode
- Minimum time between SSI clock trains 250 usec

All Models

- One channel of 24 or 25 bit binary or Gray code SSI transducer emulation
- Maximum SSI CLK rate of 500 KHZ
- Maximum SSI update rate of 4 KHz
- 28 MHz 89C450 processor with 1KB local RAM
- Sixty-four words of non-volatile EEPROM storage
- Power requirements: 7.5 – 26 VDC at <300mA (optional features may consume more current)
- Enclosure is 4.64 inches deep x 5.31 high x 1.77 wide (118 x 135 x 46 mm)
- Enclosure occupies 1.77 inches (45 mm) of DIN rail space

- Ordering Info:

Specify model: **SAB-E-?-SSI-EMUL**

To convert Start/Stop or PWM to SSI specify **SAB-E-R-SSI_EMUL**

To convert Analog voltage to SSI specify **SAB-E-A-SSI_EMUL**

Contents

General Operation SAB-E.....	1
SAB-E SSI timing	1
SAB-E-R SSI value.....	2
SAB-E-R SSI Timing	2
SAB-E-A SSI value.....	3
SAB-E-A SSI Timing.....	3
Status	3
Status Relay:.....	3
Setup.....	4
SAB-E-A Analog input select	5
SAB-E-A Analog Input Scaling.....	6
Setup Mode	7
G- Gradient:.....	7
H- Holdoff	8
S- Scale:.....	8
A- Sensor data IS or IS NOT synchronized to SSI clock	8
Remote Control	9
Remote Control protocol	9
Jumpers SAB-E.....	10
Jumper X2	10
Jumper X3	10
Jumper JP4	10
Jumper JTAG	10
Jumpers SAB-E-A Specific.....	10
Jumper X4	10
Jumper X5	10
Jumper X6, X7 and X8.....	10
Connectors.....	11
Connector JP1 (Communications DB9 male).....	11
Connector JP2 (Isolated Start/Stop or PWM Sensor connector SAB-E-R)	11
Connector JP2 (Analog input connector SAB-E-A)	11
Connector JP3 (SSI emulation connector)	11
Connector JP5 (Expansion)	12
Connections for SAB-E-A-SSI with isolated analog sensor	13
Connections for SAB-E-R-SSI with isolated sensor	14
Connections for non-isolated versions prior to Rev A	15
Connector JP1 On non-isolated expansion board (Start/Stop Sensor connector)	15
Power Consumption	16
Enclosure.....	16

General Operation SAB-E

The SAB-E module transmits a binary or Gray Code SSI data value in response to an SSI Clock input. In the Sensor Conversion mode, the value transmitted is determined by measuring the Start/Stop, PWM or Analog sensor and then scaling it using the gradient, desired SSI resolution and the Scale. In the Remote Control Slave mode the SSI value output is directly controlled by a host device over the RS232/485 serial link and the sensor measurement is not used.

At power-on the board reads dip switch 7 to determine the operational mode, Sensor Conversion (SW 7 OFF) or Slave (SW 7 ON). In the Sensor Conversion mode the module immediately sends version and setup information over the RS232 port at 9600 baud. It immediately begins outputting the SSI data in response to the SSI clock. The sensor conversion process is synchronized with the start of the SSI clock and will provide the data for the next SSI clock train.

In the Slave Mode the module responds to serial commands from the host. The slave mode baud rate is determined in the Setup Mode. The SSI value is determined by the commands from the host.

If dipswitch 8 is 'ON' the module will enter the Setup Mode allowing baud rate and other items to be changed.

SAB-E SSI timing

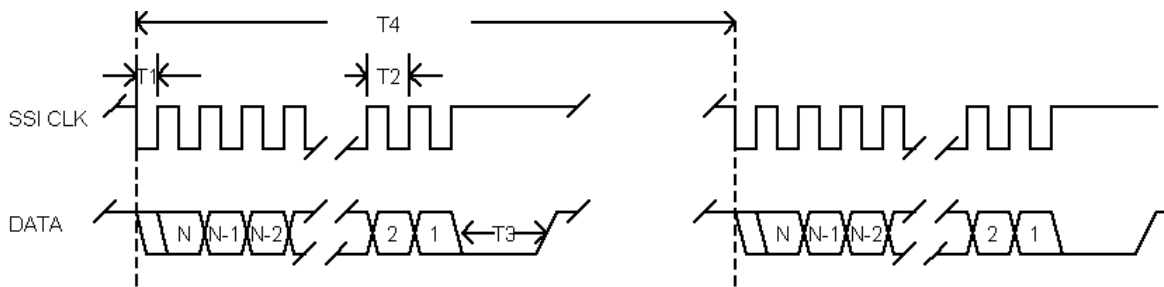

SSI TIMING

T1 - Min of 1 usec

T2 - Min of 2 usec but is controlled by cable length

T3 - 25 usec

T4 - Min of 250 usec

SAB-E-R SSI value

For the SAB-E-R module the value transmitted in response to the SSI clock is determined by the transducer measurement resolution and the entered Scale value. The PWM or Start/Stop transducer is measured with the resolution requested by dipperswitches 3,4 and 5 and the entered sensor Gradient. The value measured is multiplied by the Scale value before it is output. If for example the Scale is 0.5 then the SSI output will be 1/2 of the measured value. The default Scale is 1.0.

SAB-E-R SSI Timing

For the SAB-E-R module the interrogation of the sensor occurs on the leading edge of the SSI clock train. The resultant value will be loaded on the trailing edge of the next SSI clock train. If the measurement takes longer than the SSI update time the last completed measurement will be resent. Measurements may overlap the SSI update times. PWM gates may be asynchronous i.e. internally interrogated.

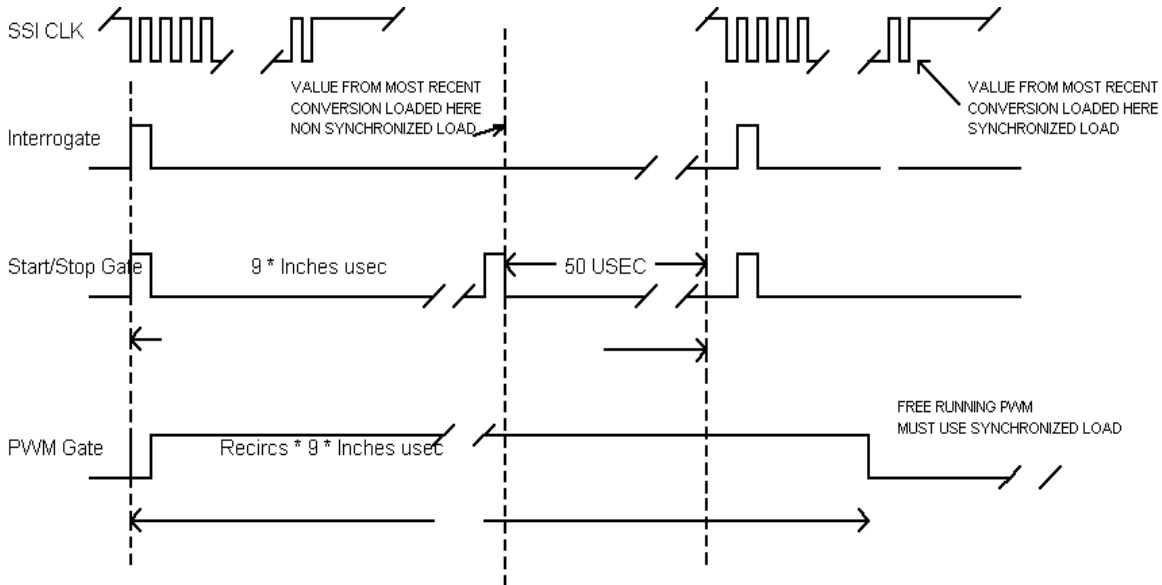

SAB-E-R Start/Stop TIMING

SAB-E-A SSI value

For the SAB-E-A module the value transmitted in response to the SSI clock is determined by the input voltage and the Scale value. The analog input is measured with a resolution of 1/65536 yielding a digitized value in the range 0 to 65535. The value measured is then multiplied by the Scale value before it is output. If, for example, the scale is 0.5 the maximum SSI output will be $\frac{1}{2}$ of 65535 or 32768 and the value of each SSI count will be doubled. The scale value can be greater than 1.0, but with a resultant loss in resolution. For example, a scale of 2.0 will yield a maximum SSI count of 131070. The default scale is 1.0.

SAB-E-A SSI Timing

For the SAB-E-A module the SSI clock trains must be separated by 250 usec.

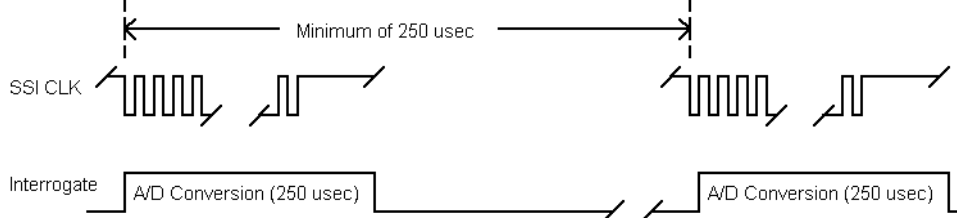

SAB-E-A Analog conversionTiming

Status

A red LED on the board blinks during operation. The red Led blink rate indicates the update rate of the SSI clock. Each 500 occurrences of the SSI clock train changes the state of the red LED. If the SSI clock is occurring at a 1 KHz rate the red LED will blink at a 1Hz rate. When you are in the setup mode the light will be steady red. If the SSI clock is missing the red led will blink very fast.

Two green LEDs indicate the status of the transducer and the SSI Clock. A lit Sensor Status LED indicates that the transducer is responding correctly. When the Sensor Status led is off, a value of 0 is sent over the SSI to indicate a bad status condition. Transducer status information is appended to the “back porch” of the SSI data stream with a low indicating good sensor status and a high indicating a fault. The “back porch” is the time period following the least significant bit and ending 25 microseconds after the last clock. A controller can sample the data at this time to determine the condition of the sensor. Rockwell motion controllers require this data to be low indicating a good sensor and high indicating a fault.

A lit SSI Status LED indicates that the SSI CLK is being received.

Status Relay:

A set of relay contacts are provided to indicate sensor status to a host device. These pins are open if the sensor is not good and closed if the green Sensor Status led is lit. These contacts are across JP1-5 and 6. The sensor is always considered good for the SAB-E-A.

Setup

The dip switches are used to configure the SSI Emulator or force it into the Setup Mode. The Dip switches are sampled when power is applied. To make changes effective cycle the board power. When Dip Switch 8 is 'ON' the device will enter the Setup Mode. When Dip Switch 8 is OFF the device will enter the Normal Operation Mode.

Switches 1 and 2 of dip switch S1 are used to select the SSI emulation as follows:

S1-1	S1-2	SSI Emulation
OFF	OFF	24 Bit Binary
ON	OFF	25 Bit Binary
OFF	ON	24 Bit Gray Code
ON	ON	25 Bit Gray Code

Switches 3, 4 and 5 (SAB-E-R only) of dip switch S1 are used to select the transducer measurement resolution, which is the value of the Least Significant Bit in the SSI data train. The values shown are for a single recirculation. If a PWM sensor is used, the values shown will be divided by the number of recirculations set in the sensor. I.E with switches 3, 4 and 5 off and a 2 recirculation sensor attached the actual resolution will be 2.5 microns.

S1-3	S1-4	S1-5	Measurement resolution	Per Inch Scale = 1.0
OFF	OFF	OFF	5 microns	5080
ON	OFF	OFF	10 microns	2540
OFF	ON	OFF	20 microns	1270
ON	ON	OFF	50 microns	508
OFF	OFF	ON	0.00025 inch	4000
ON	OFF	ON	0.0005 inch	2000
OFF	ON	ON	0.001 inch	1000
ON	ON	ON	0.002 inch	500

In the Sensor Measurement Mode, the actual value transmitted over the SSI data lines in response to the SSI clock, is determined by several dip switch and setup items. If the correct gradient is entered and the scale is 1.0 a change of magnet position of 1 inch should produce a change in SSI output value of (1 / resolution).

Switch 6 (SAB-E-R only) indicates the type of Transducer interface that is being measured

S1-6	Sensor Interface
OFF	Start/Stop
ON	PWM

Switch 7 determines the source of the SSI value. When switch 7 is 'OFF' the SSI value that is output is determined by the sensor and the associated scaling. If switch 7 is 'ON' the SSI value is controlled by serial commands from a remote host device. See section Remote Control.

S1-7	Remote Control
OFF	SSI value is sensor value
ON	SSI value is controlled by serial commands from Remote Host

Switch 8 is used to force the Emulator into the Setup mode at power on.

S1-8	Setup Mode
OFF	Normal Operation
ON	In Setup Mode

SAB-E-A Analog input select

For the SAB-E-A module has a choice of two analog inputs; high level single ended or differential instrumentation amplifier. Jumper X4 selects which of these inputs is presented to the A/D converter. When Jumper X4 is installed 2-3 then the analog value at JP2 pin 1 is connected directly to the a/d converter filter without amplification. It is referenced to pin 2 , analog common.

When Jumper X4 is installed 1-2 then the output of the instrumentation amplifier is connected to the a/d converter filter input. The instrumentation amplifier allows low level signals to be amplified and has a differential input for noisy environments. When Jumper X5 is removed the gain of the instrumentation amplifier is 1.0. allowing a differential input for high level signals. When jumper X5 is installed the GAIN pot can be adjusted for gains from 2 to 10000. When using a differential analog input connect the dc common of the source to JP2 -2 Analog common.

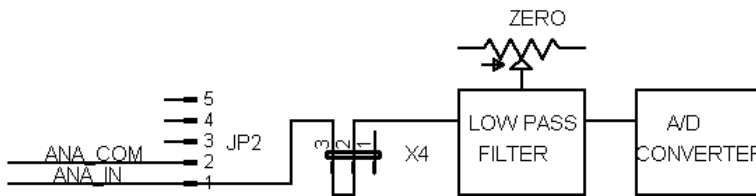

High Level Input (X4 2-3)

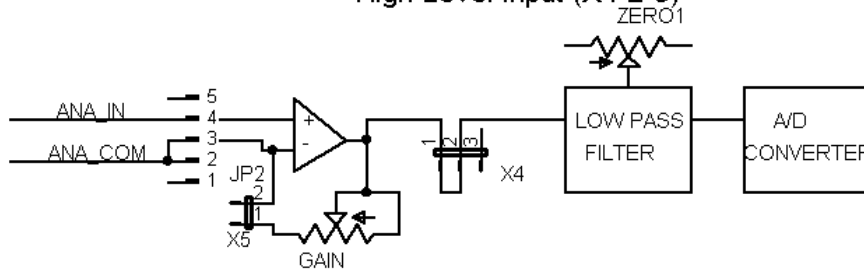

Differential Input X4 1-2 (No Gain X5 Removed)

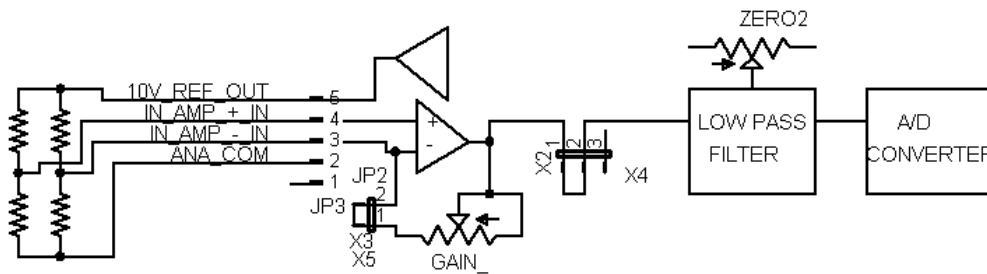

Differential Input X4 1-2 (With Gain X5 Installed)

SAB-E-A Analog Input Scaling

The SAB-E-A module converts the analog input to a count value based on the A/D converter range jumpers. The range jumpers are set to +/- 10V at the factory but can be changed to accommodate 0 to 10V. The A/D converter divides the input range into 63858 parts, multiplies this value by the scale and then presents these counts on the SSI interface as SSI counts. The table below gives the values for the two common ranges supported.

INPUT RANGE	X6	X7	X8	Maximum usable	MilliVolts / SSI Count (Scale = 1.0)
-10V to +10V	1-2	1-2	1-2	-10.27V to +10.27V	0.31332216
0 to 10V	2-3	2-3	2-3	0 to 10.27V	0.15666108

To calculate what the value of each SSI count is in the units of the input sensor divide the sensors full scale range in units by 63858. Remember that the full-scale range is the number of units from -10V to +10V or 0 to 10V depending on the sensor and the a/d converter input range.

Example 1: (Scale = 1.0)

Assume you have a 100 mm sensor that outputs -10V fully retracted and +10V fully extended . You must use the -10V to +10V a/d range and the Units per SSI count will be $(100\text{mm} / 63858) = 0.001565975\text{mm/SSI count}$.

Example 2: (Scale = 1.0)

Assume you have a 750 PSI pressure sensor that outputs 0V at 0 PSI and +10V at 750 PSI You can use the 0V to +10V range and the units per SSI count will be $(750\text{ PSI}/63858) = 0.011745\text{ PSI/SSI count}$.

Example 3: (same as example 2 but the scale is set to correct to an even number of PSI/SSI count)

Assume that in example 2 you would like each SSI count to have weight of $1/100^{\text{th}}$ PSI. You can accomplish this using the scale. To obtain the scale divide the PSI/SSI count obtained in the example 2 calculations by the desired PSI/SSI count. $0.011745/ 0.01 = 1.17448$. Enter this value as the scale. The measurement resolution is not increased but the values output on the SSI data lines are multiplied by the scale before being output.

Expanded range

The voltage input to the module is actually scaled down by a factor of 0.974 before being presented to the a/d converter. This is done to allow for a small amount of inaccuracy in the placement of linear sensors in hydraulic cylinders. The a/d converter saturates when it's input reaches -10V or +10V preventing a change in feedback beyond these values. By scaling the input down the effective range is increased to +/- 10.26V. When you use the 0 to 10V range the range is limited to 0 to 10.26 volts. The range is not increased below 0 but is increased above 10V. A slight loss in measurement resolution is another result of the expanded range.

Setup Mode

The setup mode allows setting of the gradient variable, the update time, the remote control baud rate and viewing of the sensor data via a terminal or terminal emulator such as HyperTerminal. Turn Dip Switch 8 ON and then power cycle the unit to enter the setup Mode. The unit will respond with a Software version banner on the serial port at 9600 baud, 8 bits , No parity and 1 stop bit. A menu will prompt for the setup values. After changing the values you may save them to the EEPROM. Turn Switch 8 OFF and then power cycle the unit. The new value will then be in effect.

The SAB-E-A Setup Menu:

```
Rapid Controls ANALOG to SSI Converter Nov 21 2006
SSI length: 25 bit
SSI format: binary
Sensor is Analog
Setup Mode for Rapid Controls Analog to SSI converter
Select item to change
B - Remote Control Comm Baud Rate    9600
N - Remote Control Node ID 1
L - Analog Filter length 1
S - Scale 1.0000000
V - View sensor position
E - Save to EEPROM
F - Factory Defaults
Q - Quit Menu
```

The SAB-E-R Setup Menu:

```
Rapid Controls RPM to SSI Converter Nov 21 2006
SSI length: 25 bit
SSI format: binary
SSI Resolution: 0.005 mm
Sensor is Start/Stop
Sensor Gradient is: 9.0000000
Sensor Scale is: 1.0000000
Setup Mode for Rapid Controls RPM to SSI converter
Select item to change
B - Remote Control Comm Baud Rate    9600
N - Remote Control Node ID 1
G - Gradient 9.0000000
H - Holdoff 7
A - Sensor data IS synchronized to SSI Clock
S - Scale 1.0000000
V - View sensor position
E - Save to EEPROM
F - Factory Defaults
Q - Quit Menu
```

G- Gradient:

The gradient would typically be the value read from the sensor housing and is used to calibrate the module to the sensor. The default value is 9.0 microseconds per inch. This item is not visible on the SAB-E-A module.

H- Holdoff

The Holdoff time is the time when gate pulses are blocked from the sensor immediately after the interrogate signal is issued. Occasionally sensors will have a sporadic or false gate which can be blocked by extending the holdoff time. A high holdoff value can make a sensor appear not to work when the magnet is close to the head.

The Holdoff function is not used when the PWM mode is selected.

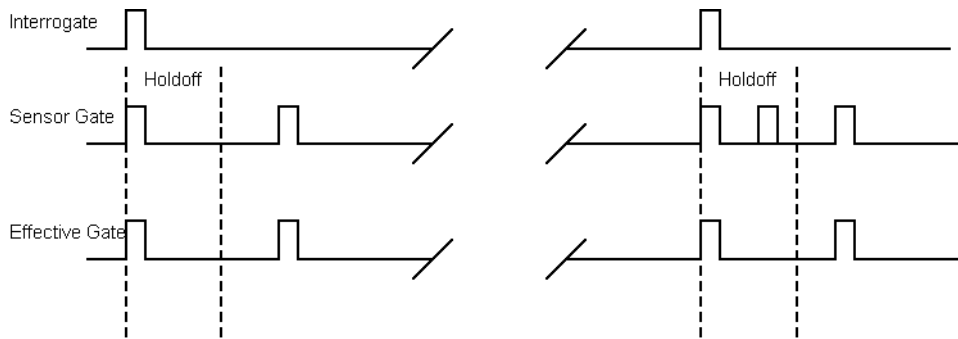

HOLDOFF TIMING

S- Scale:

The scale is applied to the sensor position data before it is presented to the SSI output. The scale allows the output value to be adjusted for units other than the values selected by the dipswitch or to adjust for recirculations. For example if you were using a PWM sensor with 4 recirculations you could apply a scale of 0.25 to adjust the output to 1 recirculation. The default value of the scale is 1.0.

A- Sensor data IS or IS NOT synchronized to SSI clock .

This setting can be used to optimize the availability of the converted data to the SSI clock. The data resulting from the conversion of the start/stop or PWM sensor can be loaded as soon as it's available (not synchronized) or wait for the end of the next SSI clock (synchronized). Loading it immediately will make it available for the next SSI clock train to read. However, in the event that the time required to convert the sensor data is longer than the time between SSI clock trains or if the sensor is an asynchronous PWM sensor the data load must be synchronized to the SSI clock to avoid loading the data while the SSI clock is active. The time required to convert the data for a Start/Stop sensor is approximately $9 \times$ the sensor length in inches. The required for a PWM sensor is $9 \times$ the sensor length in inches \times the number of recirculations. If this time exceeds the time between SSI clock trains or the PWM signal is asynchronous (internally interrogated) then the setting should be set to IS synchronized. The default value is 'IS' synchronized.

F- Factory Defaults

Returns all setup values to the factory defaults.

E- Save to EEPROM

Saves the current values to the EEPROM. Any setup changes will be lost once power is cycled until saved.

V- View Sensor Position

Use this item to see the converted value of the sensor. The numeric value printed is the value loaded into the SSI transfer register. A change of 1 count represents a change of 1 count in the emulated SSI value. The printed value is scaled using the scale, resolution and gradient settings from the dipswitch and setup items.

Remote Control

When dipswitch 7 is 'ON' the device is in Remote Control mode and is controlled by commands from the serial port. A sensor is not necessary in this mode. When the Remote Control dipswitch is on, the serial port is configured for the baud rate defined in the setup mode and the module is silent (the status messages are not printed) at power on. It responds only to valid commands to it's node id.

The Baud Rate for Remote Control is determined in the Setup Mode.

Remote Control protocol

Remote Control commands consist of the ASCII Start of Message ('\$') character followed by the ASCII Node ID ('1','2','3','4','5','6','7','8' or '9') followed by the command and optional data followed by the message termination char(Carriage Return ASCII 0xd).

The response to a good command message is the '*' character followed by the carriage return (ASCII 0xd). Response to an incorrect command will be a '?' followed by the carriage return (ASCII 0xd).

The Mode command ('M') determines the SSI mode and data length:

A 'B' character anywhere in the message will select binary operation

A 'G' character anywhere in the message will select Gray Code operation

The numeric values "24" or "25" must precede or follow the 'B' or 'G' characters.

\$1MB24 will result in 24 bit binary operation for Node 1.

\$3M25G will result in 25 bit Gray Code operation for Node ID 3

The Mode command ('P') determines the value if the SSI data:

A numeric value followed by the carriage return is interpreted as a decimal value.

A 'H' character preceding the hexadecimal numeric value followed by the carriage return is interpreted as a hexadecimal value.

\$1P210000 will result in a data value output of 210,000 for Node ID 1.

\$2PH210000 will result in a data value output of 210,000H (2,162,688 decimal) for Node ID 2.

The Version command 'V' will return an ASCII string with the version of the software.

example:

\$1V will return:

*Rapid Controls RPM to SSI Converter Jan 10 2006

Jumpers SAB-E

Jumper X2

This jumper selects the serial communications format.

X2 1-2 RS485

X2 2-3 RS232

Jumper X3

This jumper connects the RS485 line termination resistors. Install 1-4 and 2-3 for the last board in a series of RS485 configured boards to provide line termination.

X3 1-2 Connects RS485 – to +5V pull up terminator

X3 3-4 Connects RS485 + to ground pull down terminator

Jumper JP4

This jumper must be removed for normal operation and installed to use the DALLAS MK in circuit programming software in conjunction with a programming cable.

Jumper JTAG

The JTAG jumper is used at the factory and has no function in the field.

Jumpers SAB-E-A Specific

Jumper X4

This jumper selects the Analog input to the A/D converter

X4 1-2 The output of the Instrumentation Amplifier is presented to the A/D converter

X4 2-3 The high level input from JP2-1 is presented to the A/D converter

Jumper X5

Jumper X5 allows gain adjustments on the Instrumentation Amplifier

X5 1-2 The gain is adjustable from 2 to 10000 using the Gain potentiometer.

X5 Removed The gain is fixed at 1.0

Jumper X6, X7 and X8

These jumpers select the A/D converter full scale input voltage range. +/- 10V is the factory set range but use the 0 to 10V setting for uni-polar input.

Range	X6	X7	X8
+/- 10V	1-2	1-2	1-2
0 to 10V	2-3	2-3	2-3

Use the Instrumentation Amplifier gain to accommodate other ranges.

Connectors

Connector JP1 (Communications DB9 male)

JP1 – 1	RS485 -
JP1 – 2	RS232 Receive from host
JP1 – 3	RS232 Transmit to host
JP1 – 4	DTR in (Used only for in circuit programming)
JP1 – 5	DC Common
JP1 – 6	N/C
JP1 – 7	N/C
JP1 – 8	N/C
JP1 – 9	RS485 +

Comm Cable for PC serial port

SAB-E Signal	SAB-E JP1 Pin DB9 (Male)	PC Comm DB9 (Female)
Tx Data RS232	3	2
Rx Data RS232	2	3
Gnd	5	5
DTR (Boot Programmer Only)	4	4

Connector JP2 (Isolated Start/Stop or PWM Sensor connector SAB-E-R)

On Rev A and beyond boards the start/stop sensor connector is isolated from the rest of the board and uses a 5 pin screw terminal connector:

JP2 – 1	Sensor common (Isolated from the JP3 and JP4 connectors)
JP2 – 2	Interrogate + to sensor
JP2 – 3	Interrogate – to sensor
JP2 – 4	Gate + from sensor
JP2 – 5	Gate – from sensor

Connector JP2 (Analog input connector SAB-E-A)

JP2 – 1	Hi level Analog Input
JP2 – 2	Analog common
JP2 – 3	Instrumentation Amplifier – input
JP2 – 4	Instrumentation Amplifier + input
JP2 – 5	+10V Reference Output

Connector JP3 (SSI emulation connector)

JP3 – 1	Ch0 SSI data out +
JP3 – 2	Ch0 SSI data out –
JP3 – 3	Ch0 SSI Clk in +
JP3 – 4	Ch0 SSI Clk in – (Clk #)
JP3 – 5	Status relay contact 2 (closed contacts indicate good sensor)
JP3 – 6	Status relay contact 1
JP3 – 7	+ 7.5 to +27 Volts DC to power the board
JP3 – 8	DC Common

Connector JP5 (Expansion)

JP5 is used to add expansion boards. It has no function unless an expansion board is installed.

Connections for SAB-E-A-SSI with isolated analog sensor

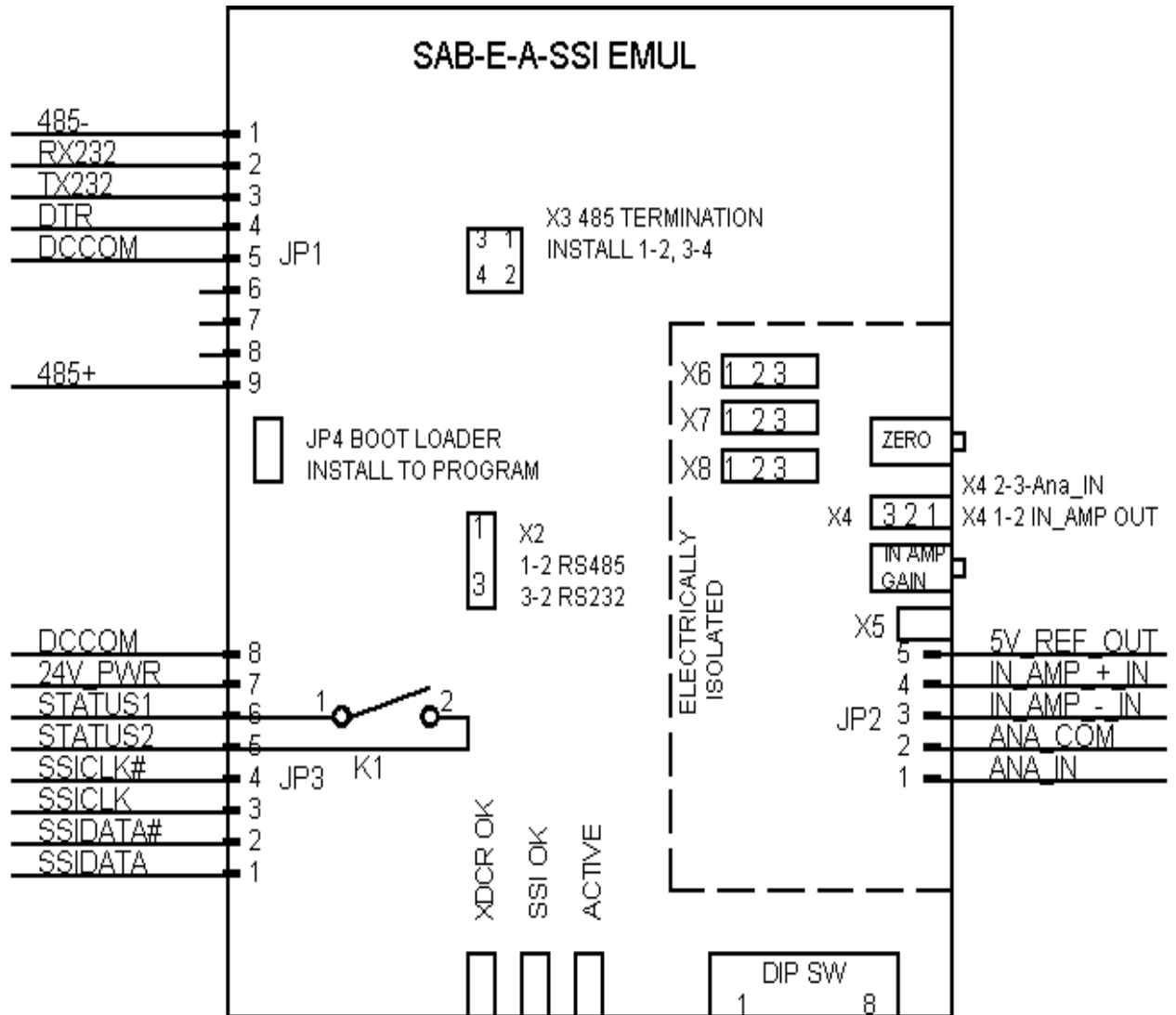

Connections for SAB-E-R-SSI with isolated sensor

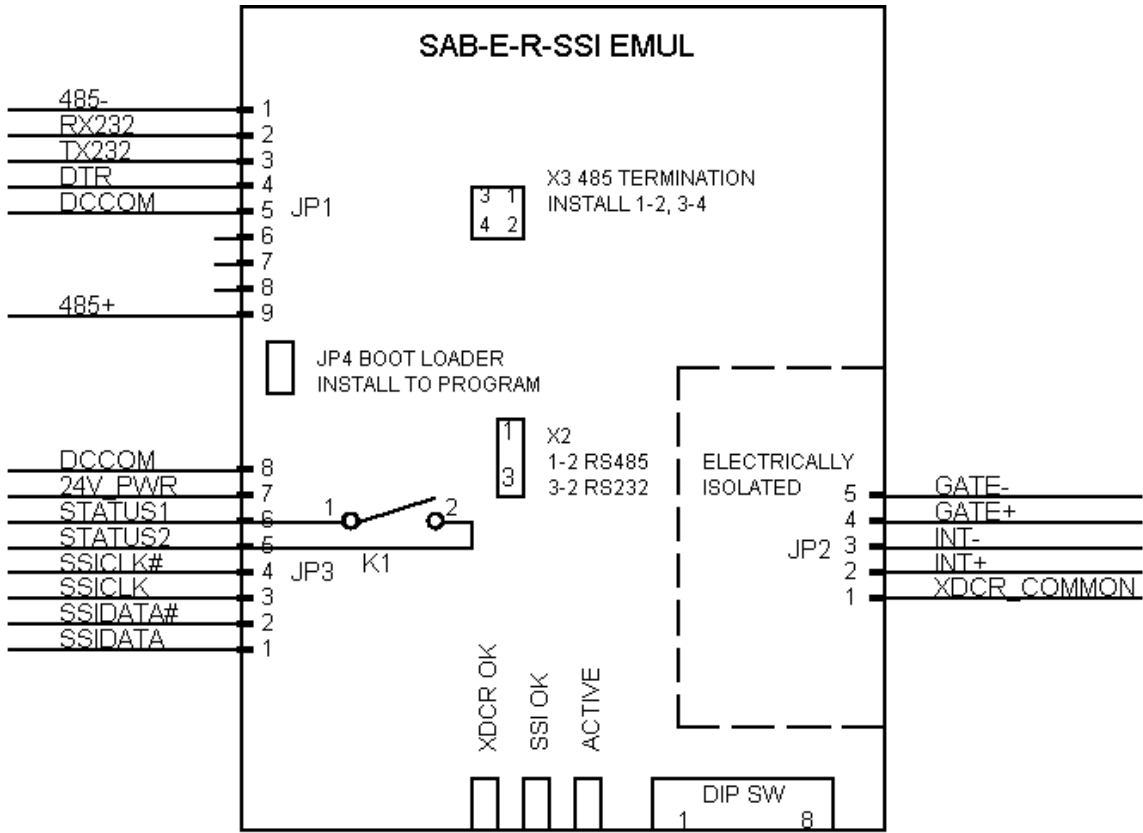

Connections for non-isolated versions prior to Rev A

Connector JP1 On non-isolated expansion board (Start/Stop Sensor connector)

- JP1 – 1 +7.5 to +26 VDC from JP3 pin 1 to be used to power the Start/Stop sensor (note)
- JP1 – 2 Power supply and signal ground
- JP1 – 3 Interrogate + to the sensor
- JP1 – 4 Interrogate - to the sensor
- JP1 – 5 Gate + from the sensor
- JP1 – 6 Gate - from the sensor

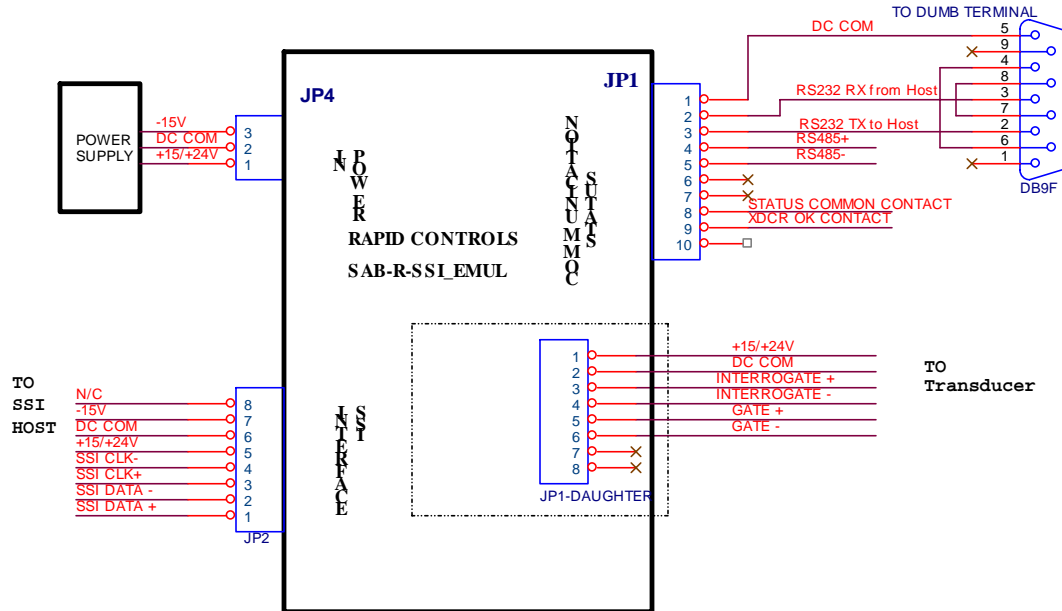

Note (1): -15V is not required by the board and is used as a connection point. Power can be supplied at JP3 or JP4, the points are connected together on the board

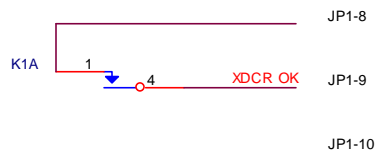

Status output relay. Contacts closed when transducer OK.

Power Consumption

The board consumes approximately 100 milliamps of the + input voltage supplied to JP4-1 for its own operation.

Enclosure

The SAB-SSI_EMUL is mounted in a DIN rail mounted enclosure, containing one or two SAB-SSI_EMUL boards. The enclosure is 4.64 inches deep x 5.31 deep x 51.77 wide, and uses 1.8 inches of DIN rail space.

