



RAPID CONTROLS

Product Specification for SAB-Q2



The SAB-Q2 module converts change in two channels of magnetostrictive transducer position to the ABZ quadrature format. The conversion is implemented with a micro-controller and EPLD allowing a wide range of flexibility and high-speed output. The module continually interrogates the magnetostrictive transducers for position and if there is a change in the position, the SAB-Q2 outputs the correct number of state changes on the AB quadrature lines. If the transducer position is the marker position, the Z quadrature output is activated. Quadrature changes are output at a rate proportional to the speed of motion. Each channel has a send all input that causes the absolute position of the transducer to be output via the quadrature lines. Each channel has a transducer OK output to signal the proper functioning of the transducer. A setup mode allows easy setup of the gradient, recirculations, offsets, marker positions, and transducer lengths, via the RS232/RS485 port.

Features

- Two channels of 24-bit position from Start/Stop, PWM or binary SSI magnetostrictive transducers
- Fast quadrature output of up to 80 inches per second with 0.001 inch resolution
- Quadrature outputs are speed proportional with selectable maximum frequency
- Marker (Z) outputs identify a unique position on each transducer
- Send All inputs cause absolute position of each channel to be output
- Transducer OK output and LED signals valid transducer operation
- Software selectable gradients, recirculations, lengths, offset, and marker position
- Setup mode uses RS232 or RS485 at 9600 baud
- Blinking LED indicates good operation of SAB-Q2
- Watchdog timer for reset upon software failure
- EEPROM for non-volatile storage of setup parameters
- Convenient screw terminal connections
- As many as four channels of differential quadrature outputs (ABZ) in a 1.77 inch DIN rail enclosure

Specifications

- Two channels of 24-bit magnetostrictive transducer measurement
- 56 MHz oscillator for 0.001 inch resolution with 2 recirculations
- Maximum SSI transducer length of 165 inches for 2 micron resolution, 412 inches for 5 micron
- Two channels of 5-volt differential A, B, and Z outputs
- Maximum Quadrature output rate selectable from 40,000, 72,000 or 112,000 quadrature states per second on each channel (10, 18 and 28 KHz)
- Update rate of 500 μ s to 14ms is automatically calculated based on transducer length and recirculations
- 28 MHz 87C520 processor with 1KB local RAM
- Sixty-four words of non-volatile EEPROM storage
- 1 to 8 recirculations for Start/Stop sensors selectable in software
- Software selectable gradient, offset, marker and length
- Two electrically isolated DC inputs for Send All (12-24 VDC)



- Two electrically isolated DC outputs for Transducer OK (0-24 VDC at 50 ma)
- Power requirements: 7.5 – 26 VDC at <300mA (optional features may consume more current)
- Enclosure is 4.64 inches deep x 5.31 high x 1.77 wide (118 x 135 x 46 mm)
- Enclosure occupies 1.77 inches (45 mm) of DIN rail space
- Enclosure can hold two boards with two channels per board
- Model SAB-Q2-ANA analog outputs:
 - Resolution is 16-bit (0.3 mV) with –10.0V to +10.0V output range
 - Output current +/-5mA

Specify model: **SAB-Q2-A-B-C**

A. Number of Channels

- 2 One 2 channel board in DIN enclosure
- 4 Two 2 channel boards in DIN enclosure

B. Transducer Interface

- RPM** Start Stop or PWM
- SSI** SSI

C. Special Options

- Omit for no special options
- ANA** Two channel 16 bit analog output

Contents

General Operation.....	1
Send All Timing.....	1
Status.....	1
Setup.....	1
Setup Considerations, Start/Stop PWM.....	1
Setup Considerations, SSI.....	2
Default Setup.....	3
Setup Operation.....	3
Setup Menu Items.....	3
Gradient.....	3
Recirculations.....	3
Scalar.....	3
Marker.....	4
Transducer Length.....	4
Transducer Type.....	4
Offset.....	4
Maximum Quadrature Speed (Units after 10/7/2005).....	4
Analog Center.....	4
Analog Range.....	4
Analog Force Flag.....	4
Analog Voltage.....	5
Save to EEPROM.....	5
Load from EEPROM.....	5
Factory Defaults.....	5
Quit.....	5
Dip Switch.....	6
Jumpers.....	6
Jumper X1.....	6
Jumper X2.....	6
Jumper X3.....	6
Jumper X4.....	6
Jumper JTAG.....	6
Jumper map.....	7
Connectors.....	8
Connector JP1.....	8
Connector JP2.....	8
Connector JP3.....	8
Connector JP4.....	9
Connector JP5.....	9
Connector J1 of the analog option board.....	9
Power Consumption.....	9
Connections.....	10
Enclosure.....	11

General Operation

At power-on the board sends version information over the RS232 port at 9600 bps, 8 data bits, no parity, 1 stop bit. It then immediately begins measuring the transducer position, and outputs any change via the quadrature interface. For Start/Stop or PWM transducers a 56-MHz counter determines the position count over the programmed number of recirculations, for SSI the value is read from the transducer. A gradient scalar is applied to normalize Start/Stop and PWM transducers. Each count is represented by an output quadrature state. The count value is continually checked to see if it matches the marker position of the channel and if so the 'Z' output is set active. In the event the host requires the absolute position of the magnet on the transducer, it can be retrieved by applying 12-24 VDC across the 'Send All' input and the input common. The unit will respond by sending the absolute measured position minus the offset, via the quadrature interface.

The SAB-Q2-ANA model also has two channels of analog output. Output is based on position and can vary from -10.0V to +10.0V.

Send All Timing

Send all pulses must be active for a minimum of 50ms before the SAB-Q2 will act upon them. A second send all cannot be activated until 500ms after the first has completed. The quadrature output will be transmitted at the maximum speed as determined by the Quadrature speed setting.

Status

A red LED on the board blinks during operation, and is lit solid while in setup mode. Two green LEDs indicate the status of the transducers. A lit LED indicates a good transducer, and a dim or dark LED indicates a missing or failing transducer or magnet.

At power-on, the board will print a sign-on message indicating the date of software in the board and the status of the retrieval of data stored in the EEPROM. A message similar to the following is displayed:

```
Rapid Controls Inc. SAB-Q [05/27/99]
Copyright(c) 1997-1999 Rapid Controls Inc.
EEPROM load successful.
```

Setup

Setup can be accomplished with a terminal or computer connected to the JP1 (host) connector. If the host desires to enter the 'Setup Mode' the host should send three characters rapidly at 9600 bps, using 8 data bits, no parity bits, and 1 stop bit until the board acknowledges with a setup menu. The board is then in 'Setup Mode' and will not output any further information on the quadrature interface until 'Setup Mode' is exited. Setup values are stored in non-volatile EEPROM memory. The required items for setup are transducer type, transducer length, transducer gradient, and the number of recirculations. The marker and offset settings are optional. The transducer gradient is optional for SSI applications.

Setup Considerations, Start/Stop PWM

The number of recirculations will determine both the resolution and the time required for the update of the Start/Stop or PWM transducer. It also has a direct effect on the speed that the magnet can travel and still have the quadrature output follow. Do not use more recirculations than necessary if travel speed is a consideration. Update times greater than 1 millisecond will have slower than maximum quadrature output speed.

A single recirculation is the time it takes for the propagation of the signal from the magnet to the receiver of the transducer. The signal travels at approximately 9 microseconds per inch (the transducer gradient). Using more than one recirculation allows greater measurement resolution but requires more time per update. The following table indicates the resolution and time versus the number of recirculations.

Recirculations	Update time for 32 inch transducer	Resolution
1	500 μ s	0.002 in
2	1000 μ s	0.001 in
4	1500 μ s	0.0005 in
8	3000 μ s	0.00025 in

Setup Considerations, SSI

The recommended SSI transducer is a synchronous 24-bit binary SSI. A 25-bit binary will also work except the effective resolution will be double that of the transducer specified (less counts per unit than specified by the model number). Asynchronous operation is also acceptable, but may perform slightly worse than synchronous. The model number of transducer chosen will determine the resolution of the data coming from the transducer. The length of the transducer will determine the time required to get the data from the transducer and will determine the minimum acceptable update time. The resolution of the transducer has a direct effect on the speed that the magnet can travel and still have the quadrature output follow without delay. Do not specify more resolution than necessary if travel speed is a consideration. The SSI transducer will require approximately 9 microseconds for each inch. The factory default setup will have to be changed to optimize SSI use. Change each channel to 1 recirculation and set the transducer length correctly. If you are using a synchronous transducer then make sure the update time is 1 millisecond for transducers less than 68 inches long or 2 milliseconds for all others. The gradient is ignored for SSI use. SSI transducers can have their output divided by 2, 4, 8, or 16 by changing the transducer type. This can be used to adjust the effective resolution of the transducer if a transducer with too high a resolution is ordered. The scalar can also be used to reduce the resolution in a more exact manner.

SSI length	Minimum update time	Max allowable resolution
Up to 55 inches	500 μ s	2 micron
Up to 110 inches	1000 μ s	2 micron
Up to 220 inches	1500 μ s	5 micron

Models prior to 10/7/2005

Transducer Resolution	Maximum Travel Speed
2 micron/count	6 inches/second
5 micron/count	15 inches/second
10 micron/count	30 inches/second
20 micron/count	60 inches/second
50 micron/count	150 inches/second
100 micron/count	300 inches/second

Models after 10/7/2005

Transducer Resolution	Maximum Travel Speed in 150 KHz Quadrature output mode
2 micron/count	11 inches/second
5 micron/count	29 inches/second
10 micron/count	58 inches/second
20 micron/count	116 inches/second
50 micron/count	290 inches/second
100 micron/count	580 inches/second

Default Setup

The default setup is programmed at the factory and is available via the 'Factory Defaults' setup command.

Setup item	Default Value
Recirculations	2
Marker Position	4000 counts
Transducer Type	Start/Stop
Transducer length	84 inches
Scalar	1.0
Offset	0 counts
Gradient	8.928571 microseconds per inch
Maximum Quadrature Frequency	28 KHz
Analog Center*	0 counts
Analog Range*	32767 counts
Analog Force Flag*	0 (off)
Analog Voltage*	0.0 Volts

*Only on the SAB-Q2-ANA model

Setup Operation

Note: Setup is meant to be performed off line. Quadrature is not output during setup.

To start the setup process, connect a 9600-bps terminal to the serial port and press the space bar several times. As soon as the board notices the incoming serial data it enters the setup mode. Once in the setup mode the quadrature ceases to function. A menu will appear offering various setup possibilities. In addition status information will be displayed, including the currently measured transducer position in counts, minus the offset. To exit the setup mode, choose 'Quit' from the setup menu or cycle the power to the board.

Setup Menu Items

Gradient

The gradient is the time it takes for the signal sent through the transducer to travel one inch. This value is measured at the factory and is stamped on the head of the transducer. Valid values are from 8.928571 to 9.999999. This change is effective immediately.

Recirculations

The number of recirculations directly affects the precision of the positions measured by the transducer. Valid values are from 1 to 8. This change is effective immediately.

Scalar

The scalar is multiplied by the transducer output before quadrature is output. This allows output of an arbitrary number of units per count. The scalar must be less than or equal to 1.0. The scalar takes effect after any shifting of SSI position occurs.

Example 1:

A start/stop sensor is being used, and normally has a resolution of 0.002 inches per count with one recirculation. The desired quadrature output is 20 counts per inch. 20 counts per inch is equivalent to 0.05 inches per count. To find the needed scalar, divide the transducer's resolution by the desired resolution. In this case, $0.002 / 0.05 = 0.04$. *Enter a scalar of 0.04.*

Example 2:

A 24-bit SSI sensor is being used, and normally has a resolution of 5 micron per count. The desired quadrature output has a resolution of 0.001 inches per count, or 25.4 micron per count. To find the scalar, divide the transducer's resolution by the desired resolution. In this case, $5 / 25.4 = 0.19685$. *Enter a scalar of 0.19685.*

Example 3:

The same 24-bit SSI sensor is used, with a resolution of 5 micron per count and the transducer type is set to SSI/2. The transducer type divides the resolution of the transducer in half, giving a resolution of 10 micron per count. The desired quadrature output has a resolution of 0.001 inches per count (25.4 micron per count). To find the scalar, divide the transducer's resolution by the desired resolution. In this case, $10 / 25.4 = 0.39370$. *Enter a scalar of 0.39370.* The resolution of the quadrature output in example 2 and example 3 is the same.

Marker

The quadrature Z output is active when the absolute position of the transducer minus the offset is equal to the marker position. The marker is not output until setup mode is exited.

Transducer Length

The length of the transducer effects the update time for the transducer. If the update time is not long enough, the positions returned from the transducer will be erratic.

Transducer Type

Select Start/Stop, PWM or SSI. An SSI designation with a slash (/) indicates division by the number following the slash. Division can be used to reduce the effective resolution of the sensor – this can be useful if velocity in counts/second is greater than the SAB-Q2 can support.

SSI Protocol

Select the SSI protocol used by the sensor. This configuration is only valid for SSI sensors and is ignored for all other sensor types. Binary protocol SSI sensors output position as a binary word. Gray code protocol SSI sensors output position using reflected binary code, or Gray code.

Offset

The offset is subtracted from the position returned from the transducer before calculating marker output, analog output, and send all.

Maximum Quadrature Speed

The maximum frequency of the quadrature output is settable. 28 KHz is the factory default and was the only maximum frequency prior to 10/7/2005.

Pre Quadrature Frequency	Post Quadrature Frequency
10 KHz	40 KHz
18 KHz	72 KHz
28 KHz (default)	115.2 KHz

Analog Center

Only available on the SAB-Q2-ANA model, the analog center is the position at which the analog output is 0 Volts.

Analog Range

Only available on the SAB-Q2-ANA model, the analog range is the number of counts above or below the analog center the analog output is at full scale (+/- 10.0V). i.e. if the analog center was 50,000 counts and

the analog range was 10,000 counts, analog output at 40,000 counts and below would be $-10.0V$, analog output at 50,000 counts would be $0.0V$, and output at 60,000 counts would be $+10.0V$.

Analog Force Flag

Only available on the SAB-Q2-ANA model, the analog force flag controls whether the analog output is forced to the analog voltage (see below). A setting of 0(zero) turns forcing off, and a setting of 1(one) turns forcing on.

Analog Voltage

Only available on the SAB-Q2-ANA model, the analog voltage is the voltage the analog output is forced to if the analog force flag is set to one.

Save to EEPROM

Select this item to save the values to the EEPROM. They values will not be saved until this is selected.

Load from EEPROM

Select his item to load the values from the EEPROM to memory.

Factory Defaults

Select this item to change all of the setup values to the factory defaults. Note that this does not save the factory default settings in the EEPROM.

Quit

Select this item to exit setup and begin operation. The values you have chosen will now be in effect. However any values not saved to the EEPROM will be lost when power is removed.

Dip Switch

Dip switch S1 is not used.

Configuration Jumpers

Jumper X2

This jumper selects the serial communications format.
X2 1-2 RS485
X2 2-3 RS232

Jumper X3

This jumper connects RS485 line termination resistors. Install 1-2 and 3-4 for the last board in a series of RS485 configured boards to provide line termination.

Jumper X4

This jumper is used to properly connect the transducer status outputs, based on the choice of common applied to the JP1-8 connector. The common voltage on JP1-8 is used by the send all inputs as well as the status outputs. The send all inputs are bi-directional and can work with sinking or sourcing inputs but the status outputs must be jumpered according to the choice of common applied to JP1-8.

If ground is applied to pin JP1-8 the outputs will be sinking and the jumpers must be installed 1-3, 5-7, 2-4 and 6-8. If a voltage (12 to 24V) is applied to JP1-8 the outputs will source the voltage and the X4 jumpers must be installed 1-2, 3-4, 5-6 and 7-8.

Jumpers X6 and X7

These jumpers are set at the factory as required for the supported sensor type. SAB-Q2 units supporting PWM and Start/Stop sensors have X6 and X7 set 1-2, while those supporting SSI sensors have X6 and X7 set 2-3.

Jumper X9 and X10

These jumpers are set at the factory as required for the supported sensor type. SAB-Q2 units supporting SSI sensors have X9 and X10 set 1-2, while those supporting PWM and Start/Stop sensors have X9 and X10 set 2-3.

Jumper JTAG

The JTAG jumper is used at the factory and has no function in the field.

Jumper map

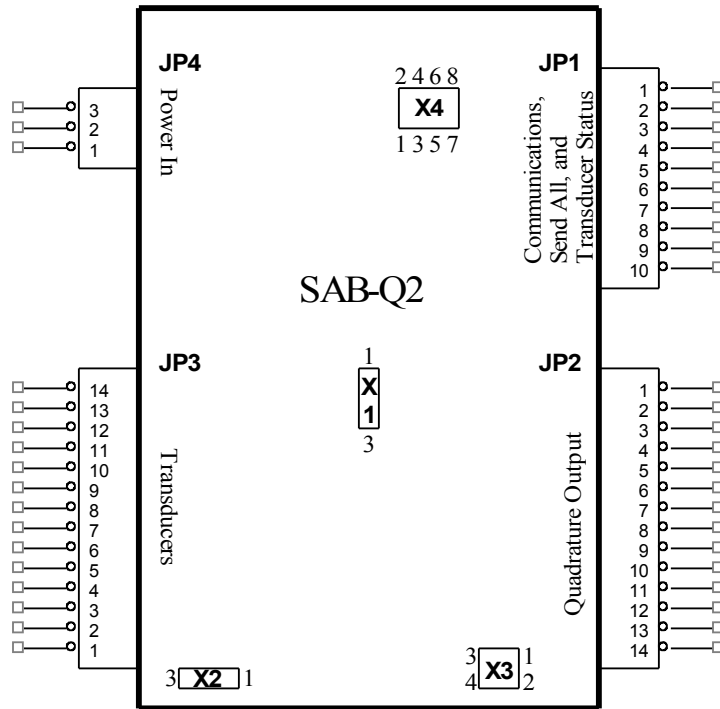

Connectors

Connector JP1

JP1 – 1	Logic Ground
JP1 – 2	RS232 Receive from host
JP1 – 3	RS232 Transmit to host
JP1 – 4	RS485 TxD/RxD- (RS485 A)
JP1 – 5	RS485 TxD/RxD+ (RS485 B)
JP1 – 6	Ch0 ‘Send All’ Input. In normal operation this input is open. When the host requires all of the position information sent it can cause current to flow between this input and JP1-8. Current flow can be in either direction. A 1.2K current limiting resistor on the board allows use with 12 to 24 VDC.
JP1 – 7	Ch1 ‘Send All’ Input. The operation of this input is the same as JP1-6.
JP1 – 8	Input common for Ch0 and Ch1 ‘Send All’ inputs.
JP1 – 9	Ch0 Transducer status output
JP1 – 10	Ch1 Transducer status output

Connector JP2

Quadrature output connector

JP2 – 1	Ch0 A
JP2 – 2	Ch0 A\
JP2 – 3	Ch0 B
JP2 – 4	Ch0 B\
JP2 – 5	Ch0 Z (marker)
JP2 – 6	Ch0 Z\
JP2 – 7	Logic ground
JP2 – 8	Ch1 A
JP2 – 9	Ch1 A\
JP2 – 10	Ch1 B
JP2 – 11	Ch1 B\
JP2 – 12	Ch1 Z (marker)
JP2 – 13	Ch1 Z\
JP2 – 14	Logic ground

Connector JP3

Transducer connector

JP3 – 1	Ch0 Interrogate + to the transducer	(YELLOW)
JP3 – 2	Ch0 Interrogate - to the transducer	(GREEN)
JP3 – 3	Ch0 Gate + from the transducer	(PINK)
JP3 – 4	Ch0 Gate - from the transducer	(GRAY)
JP3 – 5	+ Power to the transducer	(RED)
JP3 – 6	Ground	(WHITE & SHIELD)
JP3 – 7	- Power to the transducer	(BLUE)
JP3 – 8	Ch1 Interrogate + to the transducer	(YELLOW)
JP3 – 9	Ch1 Interrogate - to the transducer	(GREEN)
JP3 – 10	Ch1 Gate + from the transducer	(PINK)
JP3 – 11	Ch1 Gate - from the transducer	(GRAY)
JP3 – 12	+ Power to the transducer	(RED)
JP3 – 13	Ground	(WHITE & SHIELD)
JP3 – 14	- Power to the transducer	(BLUE)

Connector JP4

The board is powered via JP4; the board can operate on any DC voltage from 7.5V to 26VDC. However, the voltage input on JP4-1 is also passed along to the transducers via JP3-5 and JP-3-12. When using transducers requiring +24V apply +24V to JP4-1, ground to JP4-2 and do not apply any voltage at JP4-3. For transducers requiring +/- 15V apply +15V to JP4-1, ground JP4-2 and apply -15V to JP4-3.

- JP4 – 1 +7.5 to +26 VDC input the board and the transducers.
- JP4 – 2 Power supply and signal ground
- JP4 – 3 -15 VDC input to the board (for transducer requiring -15V)

Connector JP5

JP5 is used to add expansion boards. It has no function unless an expansion board is installed.

Connector J1 of the analog option board

- J1 – 1 Ch0 analog output
- J1 – 2 Analog common
- J1 – 3 Ch1 analog output

Power Consumption

The board consumes approximately 100 milliamps of the + input voltage supplied to JP4-1 for its own operation. Each transducer attached requires approximately 100 milliamps of the + input voltage for a total of 300 milliamps. The board does not require the – input voltage at JP4-3 but passes it along to the transducer.

Connections

The board and the connectors are oriented as shown here. There is a direct connection from JP4-1 to JP3-5 and 12. There is also a direct connection from JP4-3 to JP3-7 and 14. Ground is common to JP4-2, JP3-6, JP3-13, JP2-7, JP2-14 and JP1-1.

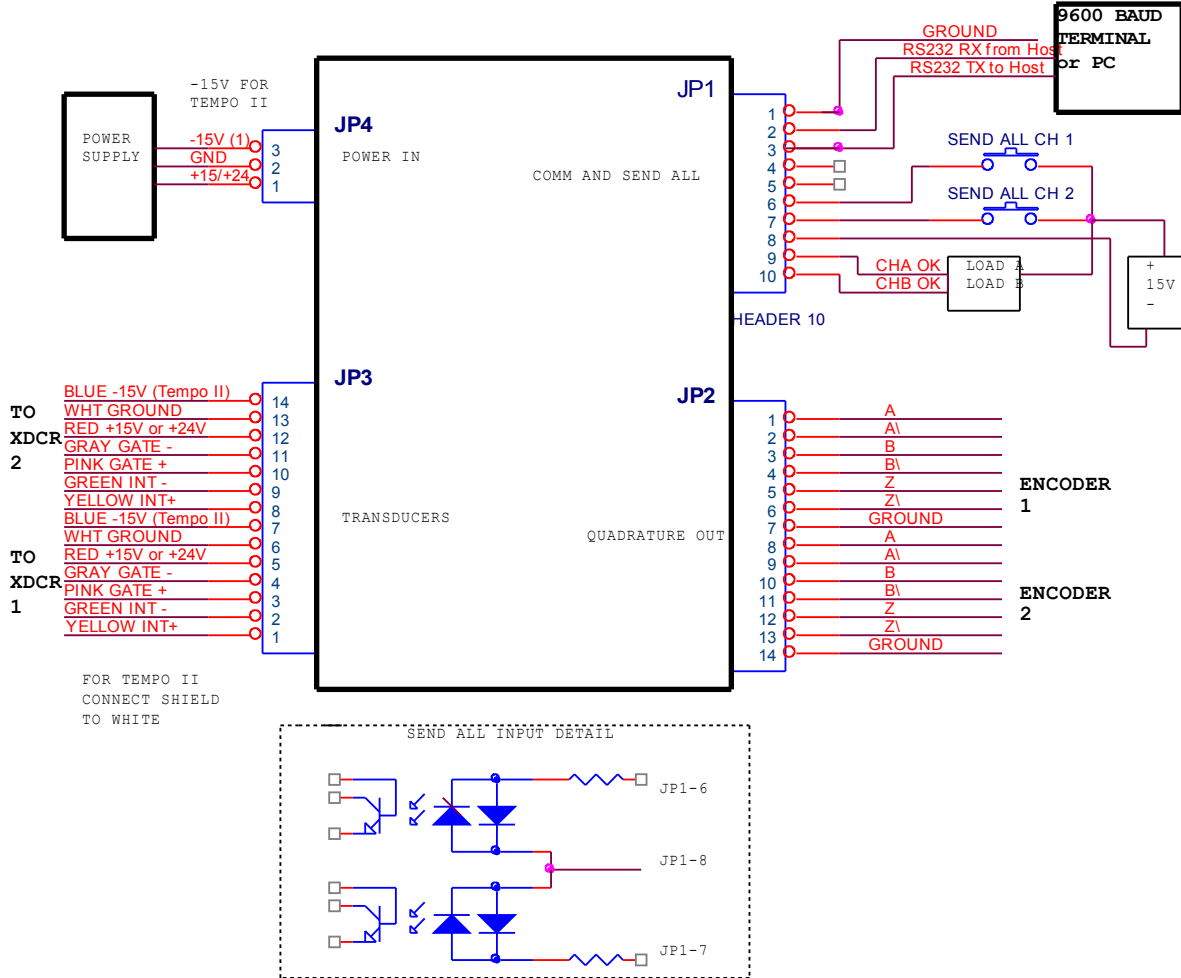

Enclosure

The SAB-Q2 is mounted in a DIN rail mounted enclosure, containing one or two SAB-Q2 boards. The enclosure is 4.64 inches deep x 5.31 high x 1.77 wide (118 x 135 x 46 mm).

This configuration can provide up to four channels of differential ABZ quadrature output based on magnetostrictive transducer input per enclosure.

