

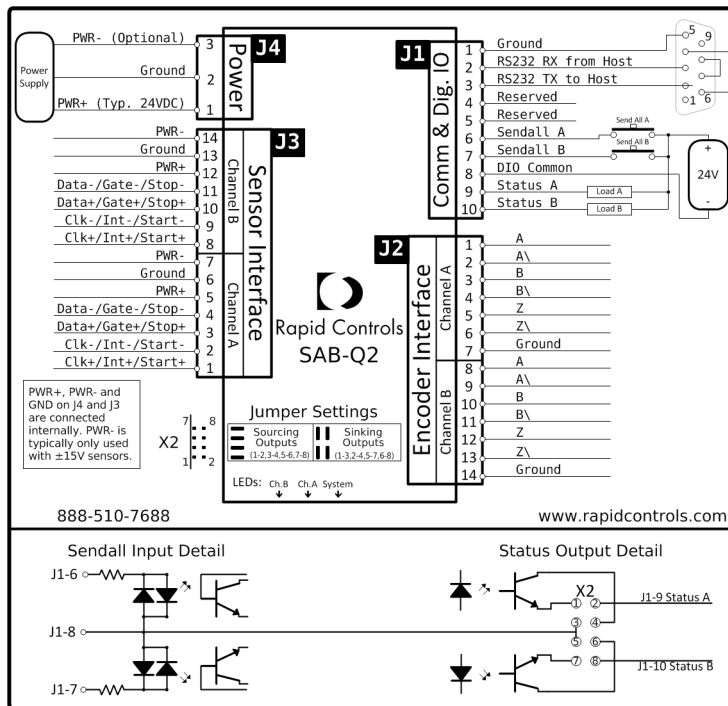

SAB-Q2 Quick Start

This document aims to provide a systematic setup procedure to enable you to setup and use your SAB-Q2 as easily as possible. This guide will concentrate on connections and basic setup. More information is available for advanced setup, refer to the SAB-Q2 manual. If you do not have a SAB-Q2 manual, call Rapid Controls or visit the Rapid Controls website, www.rapidcontrols.com.

Figure 1: SAB-Q2 Connector and Jumper Placement



1. Power Connection (Connector J4)

Power input to J4 provides power to the board and the sensors. Refer to the sensor requirements before choosing a power source for the SAB-Q2. The following pins must be connected:

Pin 1 is connected to either +24VDC or +15VDC depending on the requirements of the sensor.

Pin 2 is connected to ground.

Pin 3 is connected to -15VDC if required by the sensor. Otherwise, no connection is made.

Rapid Controls Inc.

Box 8390 ▪ Rapid City, SD ▪ 57709

Phone: 605-348-7688 ▪ Fax: 605-341-5496

<http://www.rapidcontrols.com/> ▪ email: info@rapidcontrols.com

2. Sensor Connections (Connector J3)

J3 provides the connections to the sensors. Power from J4 is passed through to the sensor on J4 pins 5, 7, 12, and 14. The following pins must be connected for operation of sensor channel 0: **(NOTE: MTS and Balluff Color Codes are specified below, other sensor manufacturers may be different):**

Pin 1 is connected to the sensor CLK+/INT+ wire (MTS: yellow; Balluff: yellow).

Pin 2 is connected to the sensor CLK-/INT- wire (MTS: green; Balluff: pink).

Pin 3 is connected to the sensor DATA+/GATE+ wire (MTS: pink; Balluff: gray).

Pin 4 is connected to the sensor DATA-/GATE- wire (MTS: gray; Balluff: green).

Pin 5 is connected to the sensor +power wire (MTS: red or brown; Balluff: brown).

Pin 6 is connected to the sensor ground wire (MTS: white; Balluff: blue). The shield may need to be connected, depending on the type of sensor.

Pin 7 is connected to the sensor –power wire (MTS: blue) if needed.

The following pins must be connected for operation of sensor channel 1:

Pin 8 is connected to the sensor CLK+/INT+ wire (MTS: yellow; Balluff: yellow).

Pin 9 is connected to the sensor CLK-/INT- wire (MTS: green; Balluff: pink).

Pin 10 is connected to the sensor DATA+/GATE+ wire (MTS: pink; Balluff: gray).

Pin 11 is connected to the sensor DATA-/GATE- wire (MTS: gray; Balluff: green).

Pin 12 is connected to the sensor +power wire (MTS: red or brown; Balluff: brown).

Pin 13 is connected to the sensor ground wire (MTS: white; Balluff: blue). The shield may need to be connected, depending on the type of sensor.

Pin 14 is connected to the sensor –power wire (MTS: blue) if needed.

3. Quadrature Connections (Connector J2)

The quadrature output from the SAB-Q2 is provided on connector J2. This connector also provides marker outputs (quadrature Z line); see the manual for details. The following connections should be made for operation of quadrature channel 0:

Pin 1 is connected to the quadrature line A input of the controller.

Pin 2 is connected to the quadrature line /A (A not) input of the controller.

Pin 3 is connected to the quadrature line B input of the controller.

Pin 4 is connected to the quadrature line /B (B not) input of the controller.

Pin 5 is connected to the marker line Z input of the controller. Optional.

Pin 6 is connected to the marker line /Z (Z not) input of the controller. Optional.

Rapid Controls Inc.

Box 8390 ■ Rapid City, SD ■ 57709

Phone: 888-510-7688 ■ Fax: 605-341-5496

<http://www.rapidcontrols.com/> ■ email: info@rapidcontrols.com

Pin 7 is connected to logic ground.

The following connections should be made for operation of quadrature channel 1:

Pin 8 is connected to the quadrature line A input of the controller.

Pin 9 is connected to the quadrature line /A (A not) input of the controller.

Pin 10 is connected to the quadrature line B input of the controller.

Pin 11 is connected to the quadrature line /B (B not) input of the controller.

Pin 12 is connected to the marker line Z input of the controller. Optional.

Pin 13 is connected to the marker line /Z (Z not) input of the controller. Optional

Pin 14 is connected to logic ground.

4. Serial Communications (Connector J1)

Connector J1 provides serial communications. The following pins must be connected for RS-232 communications:

Pin 1 is connected to logic ground on the host computer (pin 5 on a DB-9 connector, pin 7 on a DB-25 connector).

Pin 2 is the SAB-Q2's receive line and is connected to the host computer's transmit line. (pin 3 on a DB-9 connector, pin 2 on a DB-25 connector)

Pin 3 is the SAB-Q2's transmit line connected to the host computer's receive line. (pin 2 on a DB-9 connector, pin 3 on a DB-25 connector)

If the host computer requires the use of hardware handshaking, the host's DTR line must be tied to the host's DSR line (pin 4 to pin 6 on a DB-9), and the host's RTS line must be tied to the host's CTS line (pin 7 to pin 8 on a DB-9).

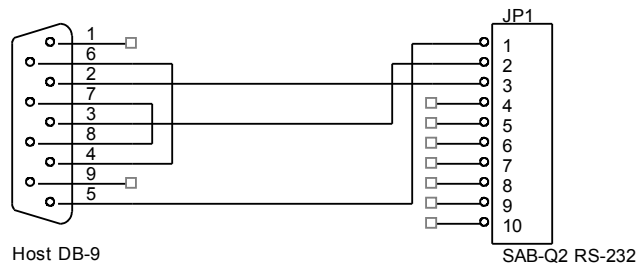

Figure 2: Diagram of SAB-Q2 RS-232 Serial Cable

Note: Wires between pins 4 and 6 and pins 7 and 8 can be omitted if host computer does not require hardware handshaking.

After connecting the host computer to the SAB-Q2 and setting the correct communications parameters, apply power to the SAB-Q2. Press the spacebar several times quickly. The SAB-Q2 will respond with a menu. If the SAB-Q2 does not present a menu, check the serial cabling and terminal software setup.

Rapid Controls Inc.

Box 8390 ■ Rapid City, SD ■ 57709

Phone: 888-510-7688 ■ Fax: 605-341-5496

<http://www.rapidcontrols.com/> ■ email: info@rapidcontrols.com

5. Send All Inputs and Sensor Status Outputs (Connector J1)

Connector J1 is also used for send all input and sensor status outputs. The two send all inputs command the SAB-Q2 to send the absolute position of the sensor over the quadrature channel. The sensor status outputs show the status of the sensors. The output will be active when the sensor is operating properly. The inputs are bi-directional and can source or sink current depending on the voltage applied to J1-8. If the controller has a sinking output apply +12 to 24 VDC to J1-8 and allow the controller to ground the appropriate send all input to cause the send all function. If the controller has a sourcing output apply ground to J1-8 and allow the controller to source +12 to 24V to the appropriate send all input to cause the send all function. The X2 jumper connects the status outputs to match the choice of common applied to J1-8. If the input common is grounded then the outputs must be jumpered to be sinking. If the input common is connected to +12 to 24V then the outputs must be jumpered to be sourcing.

Desired Input and Output Type	X2 Setup	J1-8: I/O Common	Action to Activate Inputs	Effect of Active Outputs
Sinking inputs Sinking outputs	1-3, 2-4 5-7, 6-8	Ground	Apply +12 to 24V to J1-6 or J1-7	Output will sink current through load
Sourcing inputs, Sourcing outputs	1-2, 3-4 5-6, 7-8	+12 to +24 VDC	Ground J1-6 or J1-7	Output will source grounded load

Table 1: Input and Output Configurations

The followings pins are used for the send all inputs and sensor status outputs:

Pin 6 is the send all input for channel 0. Activating this input will cause the SAB-Q2 to send the absolute position for channel 0.

Pin 7 is the send all input for channel 1. Activating this input will cause the SAB-Q2 to send the absolute position for channel 1.

Pin 8 is the I/O common. It should be connected as described in Table 1.

Pin 9 is the channel 0 sensor status output. An active output indicates a good sensor.

Pin 10 is the channel 1 sensor status output. An active output indicates a good sensor.

6. Initial Power Up

After all connections are complete and have been checked for errors, apply power to the SAB-Q2. The red board status LED should blink. A green sensor status LED should light for each connected sensor with a magnet.

If the board status LED does not blink when power is applied, check that your power connections are correct (see Section 1).

If your sensor is a PWM sensor, you must perform some setup before determining correct sensor operation. Please perform the setup described in sections 7 and 8a before continuing with this section.

If the sensor status LED(s) do not light, appear dim or flicker, check that the sensor magnet is installed as prescribed in your sensor documentation. If the LED(s) still do not light, remove power from the SAB-Q2 and verify all sensor connections.

If, after insuring the sensor connections are correct, the SAB-Q2 still does not light the sensor status LED(s), verify that your SAB-Q2 model is capable of supporting your sensor. The SAB-Q2-?-RPM

Rapid Controls Inc.

Box 8390 ▪ Rapid City, SD ▪ 57709

Phone: 888-510-7688 ▪ Fax: 605-341-5496

<http://www.rapidcontrols.com/> ▪ email: info@rapidcontrols.com

models are capable of operating with Start/Stop and PWM sensors. The SAB-Q2-?-SSI models are capable of operating with SSI sensors.

7. Sensor Setup

A. Transducer Type

The SAB-Q2 default setting is RPM. If a SSI or PWM sensor is being used then sensor type must be changed to SSI or PWM in the setup menu. Recommended SSI sensor is 24-bit binary SSI. SSI sensors can have their output divided by 2, 4, 8, or 16 by changing the sensor type. This can be used to adjust the effective resolution of the sensor if a sensor with too high a resolution is ordered.

B. Sensor Length

Enter the length of the sensor in inches. This length must be greater than the farthest distance the magnet can travel to on the wand. If this length is too small, positions from the sensor could become unpredictable.

C. Gradient

The gradient (in microseconds per inch) of a RPM or PWM sensor must be entered. This value is printed on the head of the sensor at the factory. If you are using a SSI sensor, enter a value of 1.00000.

D. Recirculations

The number of recirculations determines the worth of each count. A higher number of recirculations increases the resolution of the counts but increases the update time. The approximate value of a count can be determined through the following formula: $(0.002 \div \text{recirculations})$ inches per count.

8. Position Setup

A. Offset

The offset is subtracted from the position before calculating any analog output, before doing a send all, and when activating the marker output. Enter this value in counts.

B. Marker

The marker position is the number of counts at which the marker output is activated. See the SAB-Q2 manual for more information.

9. Further Setup

Some material related to setup of the SAB-Q2 is not covered in this guide. For more information on advanced setup, see the SAB-Q2 manual.

Rapid Controls Inc.

Box 8390 ■ Rapid City, SD ■ 57709

Phone: 888-510-7688 ■ Fax: 605-341-5496

<http://www.rapidcontrols.com/> ■ email: info@rapidcontrols.com