



## SAB-Q2 Quick Start

This document aims to provide a systematic setup procedure to enable you to setup and use your SAB-Q2 as easily as possible. This guide will concentrate on connections and basic setup. More information is available for advanced setup, refer to the SAB-Q2 manual. If you do not have a SAB-Q2 manual, call Rapid Controls or visit the Rapid Controls website, [www.rapidcontrols.com](http://www.rapidcontrols.com).

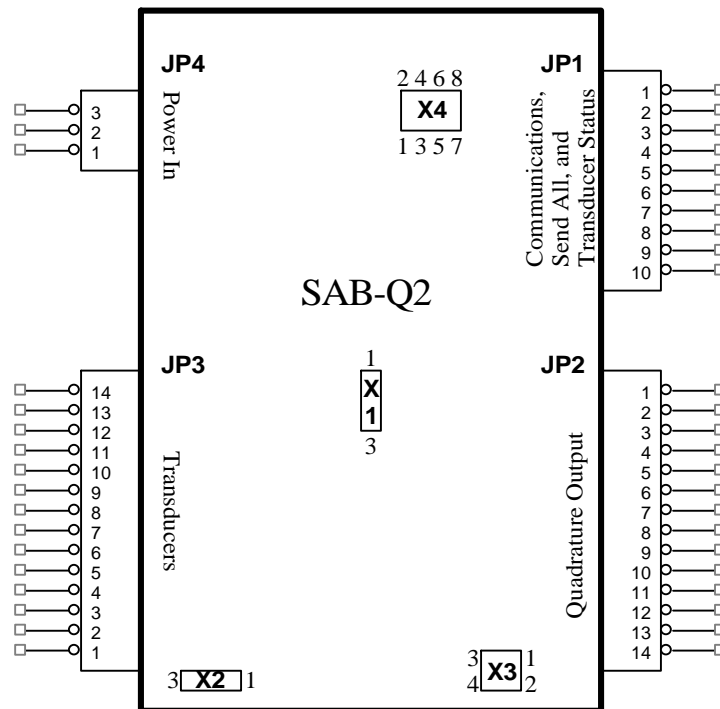

Figure 1: SAB-Q2 Connector and Jumper Placement

### 1. Power Connection (Connector JP4)

Power input to JP4 provides power to the board and the transducers. Refer to the transducer requirements before choosing a power source for the SAB-Q2. The following pins must be connected:

Pin 1 is connected to either +24VDC or +15VDC depending on the requirements of the transducer.

Pin 2 is connected to ground.

Pin 3 is connected to -15VDC if required by the transducer. Otherwise, no connection is made.

#### Rapid Controls Inc.

Box 8390 ▪ Rapid City, SD ▪ 57709

Phone: 605-348-7688 ▪ Fax: 605-341-5496

<http://www.rapidcontrols.com/> ▪ email: [info@rapidcontrols.com](mailto:info@rapidcontrols.com)

## 2. Transducer Connections (Connector JP3)

JP3 provides the connections to the transducers. Power from JP4 is passed through to the transducer on JP4 pins 5, 7, 12, and 14. The following pins must be connected for operation of transducer channel 0:

Pin 1 is connected to the transducer CLK+/INT+ wire (yellow).

Pin 2 is connected to the transducer CLK-/INT- wire (green).

Pin 3 is connected to the transducer DATA+/GATE+ wire (pink).

Pin 4 is connected to the transducer DATA-/GATE- wire (gray).

Pin 5 is connected to the transducer +power wire (red or brown).

Pin 6 is connected to the transducer ground wire (white). The shield may need to be connected, depending on the type of transducer (see included note).

Pin 7 is connected to the transducer –power wire (blue) if needed.

The following pins must be connected for operation of transducer channel 1:

Pin 8 is connected to the transducer CLK+/INT+ wire (yellow).

Pin 9 is connected to the transducer CLK-/INT- wire (green).

Pin 10 is connected to the transducer DATA+/GATE+ wire (pink).

Pin 11 is connected to the transducer DATA-/GATE- wire (gray).

Pin 12 is connected to the transducer +power wire (red or brown).

Pin 13 is connected to the transducer ground wire (white). The shield may need to be connected, depending on the type of transducer (see included note).

Pin 14 is connected to the transducer –power wire (blue) if needed.

## 3. Quadrature Connections (Connector JP2)

The quadrature output from the SAB-Q2 is provided on connector JP2. This connector also provides marker outputs (quadrature Z line); see the manual for details. The following connections should be made for operation of quadrature channel 0:

Pin 1 is connected to the quadrature line A input of the controller.

Pin 2 is connected to the quadrature line /A (A not) input of the controller.

Pin 3 is connected to the quadrature line B input of the controller.

Pin 4 is connected to the quadrature line /B (B not) input of the controller.

Pin 5 is connected to the marker line Z input of the controller. Optional.

Pin 6 is connected to the marker line /Z (Z not) input of the controller. Optional.

Pin 7 is connected to logic ground.

### **Rapid Controls Inc.**

Box 8390 ■ Rapid City, SD ■ 57709

Phone: 605-348-7688 ■ Fax: 605-341-5496

<http://www.rapidcontrols.com/> ■ email: [info@rapidcontrols.com](mailto:info@rapidcontrols.com)

The following connections should be made for operation of quadrature channel 1:

Pin 8 is connected to the quadrature line A input of the controller.

Pin 9 is connected to the quadrature line /A (A not) input of the controller.

Pin 10 is connected to the quadrature line B input of the controller.

Pin 11 is connected to the quadrature line /B (B not) input of the controller.

Pin 12 is connected to the marker line Z input of the controller. Optional.

Pin 13 is connected to the marker line /Z (Z not) input of the controller. Optional

Pin 14 is connected to logic ground.

#### 4. Serial Communications (Connector JP1 and Jumper X2)

Connector JP1 provides serial communications (in addition to other features, see below). Both RS-232 and RS-485 are available. For more information on using RS-485, see the SAB-Q2 manual. Jumper X2 must be set 2-3 for RS-232. The following pins must be connected for RS-232 communications:

Pin 1 is connected to logic ground on the host computer (pin 5 on a DB-9 connector, pin 7 on a DB-25 connector).

Pin 2 is the SAB-Q2's receive line and is connected to the host computer's transmit line. (pin 3 on a DB-9 connector, pin 2 on a DB-25 connector)

Pin 3 is the SAB-Q2's transmit line connected to the host computer's receive line. (pin 2 on a DB-9 connector, pin 3 on a DB-25 connector)

If the host computer requires the use of hardware handshaking, the host's DTR line must be tied to the host's DSR line (pin 4 to pin 6 on a DB-9), and the host's RTS line must be tied to the host's CTS line (pin 7 to pin 8 on a DB-9).

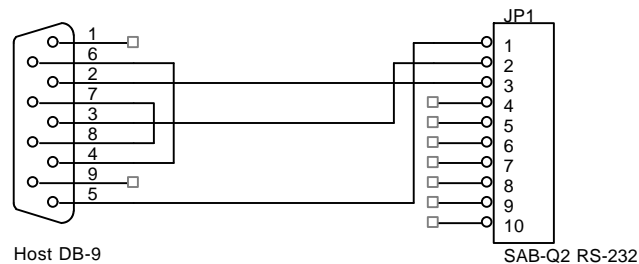

Figure 2: Diagram of SAB-Q2 RS-232 Serial Cable

Note: Wires between pins 4 and 6 and pins 7 and 8 can be omitted if host computer does not require hardware handshaking.

After connecting the host computer to the SAB-Q2 and setting the correct communications parameters, apply power to the SAB-Q2. Press the spacebar several times quickly. The SAB-Q2 will respond with a menu. If the SAB-Q2 does not present a menu, check the serial cabling and software setup, make sure jumper X2 is set correctly: 1-2 for RS485 or 2-3 for RS232.

#### Rapid Controls Inc.

Box 8390 ■ Rapid City, SD ■ 57709

Phone: 605-348-7688 ■ Fax: 605-341-5496

<http://www.rapidcontrols.com/> ■ email: [info@rapidcontrols.com](mailto:info@rapidcontrols.com)

## 5. Send All Inputs and Transducer Status Outputs (Connector JP1)

Connector JP1 is also used for send all input and transducer status outputs. The two send all inputs command the SAB-Q2 to send the absolute position of the transducer over the quadrature channel. The transducer status outputs show the status of the transducers. The output will be active when the transducer is operating properly. The inputs are bi-directional and can source or sink current depending on the voltage applied to JP1-8. If the controller has a sinking output apply +12 to 24 VDC to JP1-8 and allow the controller to ground the appropriate send all input to cause the send all function. If the controller has a sourcing output apply ground to JP1-8 and allow the controller to source +12 to 24V to the appropriate send all input to cause the send all function. The X4 jumper connects the status outputs to match the choice of common applied to JP1-8. If the common input is grounded then the outputs must be jumpered to be sinking. If the common input is connected to +12 to 24V then the outputs must be jumpered to be sourcing.

Desired Input and Output Type	X4 Setup	JP1-8: I/O Common	Action to Activate Inputs	Effect of Active Outputs
Sinking inputs Sinking outputs	1-3, 2-4 5-7, 6-8	Ground	Apply +12 to 24V to JP1-6 or JP1-7	Output will sink current through load
Sourcing inputs, Sourcing outputs	1-2, 3-4 5-6, 7-8	+12 to +24 VDC	Ground JP1-6 or JP1-7	Output will source grounded load

Table 1: Input and Output Configurations

The followings pins are used for the send all inputs and transducer status outputs:

Pin 6 is the send all input for channel 0. Activating this input will cause the SAB-Q2 to send the absolute position for channel 0.

Pin 7 is the send all input for channel 1. Activating this input will cause the SAB-Q2 to send the absolute position for channel 1.

Pin 8 is the I/O common. It should be connected as described in table 1.

Pin 9 is the channel 0 transducer status output. An active output indicates a good transducer.

Pin 10 is the channel 1 transducer status output. An active output indicates a good transducer.

## 6. Initial Power Up

After all connections are complete and have been checked for errors, apply power to the SAB-Q2. The red board status LED should blink. A green transducer status LED should light for each connected transducer with a magnet.

If the board status LED does not blink when power is applied, check that your power connections are correct (see section 1).

If your transducer is a PWM transducer, you must perform some setup before determining correct transducer operation. Please perform the setup described in sections 7 and 8a before continuing with this section.

If the transducer status LED(s) do not light, appear dim or flicker, check that the transducer magnet is installed as prescribed in your transducer documentation. If the LED(s) still do not light, remove power from the SAB-Q2 and verify all transducer connections.

If, after insuring the transducer connections are correct, the SAB-Q2 still does not light the transducer status LED(s), verify that your SAB-Q2 model is capable of supporting your transducer. The SAB-Q2-

### Rapid Controls Inc.

Box 8390 ▪ Rapid City, SD ▪ 57709

Phone: 605-348-7688 ▪ Fax: 605-341-5496

<http://www.rapidcontrols.com/> ▪ email: [info@rapidcontrols.com](mailto:info@rapidcontrols.com)

?-RPM models are capable of operating with Start/Stop and PWM transducers. The SAB-Q2-?-SSI models are capable of operating with SSI transducers.

## 7. Transducer Setup

### A. Transducer Type

If you are using a PWM transducer, you must change the transducer type to PWM. If you are using a SSI or Start/Stop transducer, choose RPM as the transducer type.

### B. Transducer Length

Enter the length of the transducer in inches. This length must be greater than the farthest distance the magnet can travel to on the wand. If this length is too small, positions from the transducer could become unpredictable.

### C. Gradient

The gradient (in microseconds per inch) of a RPM or PWM transducer must be entered. This value is printed on the head of the transducer at the factory. If you are using a SSI transducer, enter a value of 9.00000.

### D. Recirculations

The number of recirculations determines the worth of each count. A higher number of recirculations increases the resolution of the counts but increases the update time. The approximate value of a count can be determined through the following formula:  $(0.002 \div \text{recirculations})$  inches per count.

## 8. Position Setup

### A. Offset

The offset is subtracted from the position before calculating any analog output, before doing a send all, and when activating the marker output. Enter this value in counts.

### B. Marker

The marker position is the number of counts at which the marker output is activated. See the SAB-Q2 manual for more information.

## 9. Further Setup

Some material related to setup of the SAB-Q2 is not covered in this guide. For more information on advanced setup, see the SAB-Q2 manual.

### **Rapid Controls Inc.**

Box 8390 ■ Rapid City, SD ■ 57709

Phone: 605-348-7688 ■ Fax: 605-341-5496

<http://www.rapidcontrols.com/> ■ email: [info@rapidcontrols.com](mailto:info@rapidcontrols.com)