

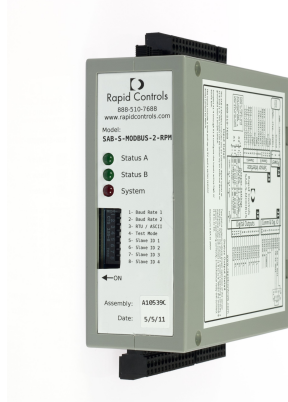

Product Specification for SAB-S-MODBUS



The SAB-S-MODBUS is a two-channel module that measures single or multiple magnet transducer position and returns this information to a host computer via a serial interface using the Modbus ASCII or RTU protocol over a RS232 or RS485 port. Communication setup is controlled via dip-switch settings and sensor interface configuration is controlled via Modbus registers.

Features

- Two channels of 32 bit magnetostrictive transducer position
- Supports Start/Stop, PWM, and SSI sensor communication protocols
- Up to 16 magnets per transducer when used with Start/Stop output sensors
- Modbus ASCII or RTU operation, switch selectable
- Compatible with any Start/Stop, PWM, or SSI output magnetostrictive transducer
- Also compatible with other SSI output sensors such as absolute encoders
- Convenient removable screw terminals for all connections
- Serial interface operates with RS232 or RS485
- 2400, 9600, 19200 and 57600 Baud, 8 Bits, No Parity, 1 Stop bit
- Blinking red LED indicates processor operation
- LED and digital output for each channel indicates sensor status
- EEPROM for nonvolatile storage of setup parameters
- +24 VDC power is distributed to the transducers

Specifications

- 2 Channels of Start/Stop, PWM, or SSI magnetostrictive transducer measurement with RS-422 levels
- 0.002 inch resolution in multi-magnet mode
- Up to 16 magnets per sensor when using a Start/Stop output sensor
- Update rate: 3 milliseconds
- RS485, RS232 at 2400, 9600, 19200 and 57600 Baud, 8 Bits, No Parity, 1 Stop bit
- 28 MHz 87C520 processor with 1K local ram
- Sixty-four words of EEPROM storage
- Two 5V DC inputs can be viewed
- Two relay contact outputs indicate transducer status
- Power: 24 VDC at < 300 milliamps
- Physical Size: 4.88 x 4.00 x 1.75 inches (occupies 1.75 inches of DIN rail space)

Rapid Controls Inc.

Box 8390 ▪ Rapid City, SD ▪ 57709

Phone: 605-348-7688 ▪ Fax: 605-341-5496

<http://www.rapidcontrols.com/> ▪ email: info@rapidcontrols.com



Contents

Operation..... 1

 Host Communications..... 1

 MODBUS overview..... 1

 Readable Coils Supported..... 1

 Readable Discrete Inputs Supported..... 1

 Readable Registers Supported..... 1

 Writeable Coils Supported..... 3

 Writeable Registers Supported..... 3

 MODBUS command details..... 4

 Read Coil Status..... 4

 Read Holding Registers..... 4

 Force Single Coil..... 5

 Preset Registers 5

Setup..... 6

Offline Test mode..... 8

Jumpers..... 8

 Jumper X1 8

 Jumper X2..... 8

 Jumper X3..... 8

 Jumper X4..... 8

 Jumper X5..... 8

 Jumper X6..... 8

Connectors..... 9

 Connector J1..... 9

 Connector J2..... 9

 Connector J3..... 10

 Connector J4..... 10

Power Consumption..... 10

Connections..... 11

Enclosure..... 12

Rapid Controls Inc.

Box 8390 ▪ Rapid City, SD ▪ 57709

Phone: 605-348-7688 ▪ Fax: 605-341-5496

<http://www.rapidcontrols.com/> ▪ email: info@rapidcontrols.com

Operation

At power on, the board immediately retrieves the setup values from the EEPROM memory and begins operation. Operation consists of interrogating both transducers during each 3ms update period and updating the position information stored in the data registers. The board allows host communications at any time.

Host Communications

The board communicates to a host computer via RS232 or RS485 using a subset of the MODBUS protocol. ASCII or RTU mode is selected by via a dipswitch. Note that all examples are given as ASCII mode. See the *Modbus Protocol Reference Guide* (available at www.modbus.org) for more information on the MODBUS protocol.

MODBUS overview

Note: When using Modbus queries, coils, registers, and input addresses start at 0. Thus the address for coil 1 is 0.

Readable Coils Supported

1	Status of Channel A: On = OK, Off = Failed
2	Status of Channel B: On = OK, Off = Failed
3	State of Discrete Output 1
4	State of Discrete Output 2
5	State of Discrete Output 3
6	State of Discrete Output 4
7	State of Discrete Output 5
8	State of Discrete Output 6

Readable Discrete Inputs Supported

1	Discrete input 1
2	Discrete input 2

Readable Registers Supported

1	Channel A, number of magnets expected (Start/Stop only)
2	Channel B, number of magnets expected (Start/Stop only)
3-32	Reserved
33	Channel A, Magnet 1 High Word Of Position (Read Only)
34	Channel A, Magnet 1 Low Word Of Position (Read Only)
35	Channel A, Magnet 2 High Word Of Position (Read Only)
36	Channel A, Magnet 2 Low Word Of Position (Read Only)
37	Channel A, Magnet 3 High Word Of Position (Read Only)
38	Channel A, Magnet 3 Low Word Of Position (Read Only)
39	Channel A, Magnet 4 High Word Of Position (Read Only)
40	Channel A, Magnet 4 Low Word Of Position (Read Only)
41	Channel A, Magnet 5 High Word Of Position (Read Only)
42	Channel A, Magnet 5 Low Word Of Position (Read Only)
43	Channel A, Magnet 6 High Word Of Position (Read Only)
44	Channel A, Magnet 6 Low Word Of Position (Read Only)
45	Channel A, Magnet 7 High Word Of Position (Read Only)
46	Channel A, Magnet 7 Low Word Of Position (Read Only)
47	Channel A, Magnet 8 High Word Of Position (Read Only)
48	Channel A, Magnet 8 Low Word Of Position (Read Only)
49	Channel A, Magnet 9 High Word Of Position (Read Only)

50	Channel A, Magnet 9 Low Word Of Position (Read Only)
51	Channel A, Magnet 10 High Word Of Position (Read Only)
52	Channel A, Magnet 10 Low Word Of Position (Read Only)
53	Channel A, Magnet 11 High Word Of Position (Read Only)
54	Channel A, Magnet 11 Low Word Of Position (Read Only)
55	Channel A, Magnet 12 High Word Of Position (Read Only)
56	Channel A, Magnet 12 Low Word Of Position (Read Only)
57	Channel A, Magnet 13 High Word Of Position (Read Only)
58	Channel A, Magnet 13 Low Word Of Position (Read Only)
59	Channel A, Magnet 14 High Word Of Position (Read Only)
60	Channel A, Magnet 14 Low Word Of Position (Read Only)
61	Channel A, Magnet 15 High Word Of Position (Read Only)
62	Channel A, Magnet 15 Low Word Of Position (Read Only)
63	Channel A, Magnet 16 High Word of Position (Read Only)
64	Channel A, Magnet 16 Low Word of Position (Read Only)
64 – 96	Reserved
97	Channel B, Magnet 1 High Word Of Position (Read Only)
98	Channel B, Magnet 1 Low Word Of Position (Read Only)
99	Channel B, Magnet 2 High Word Of Position (Read Only)
100	Channel B, Magnet 2 Low Word Of Position (Read Only)
101	Channel B, Magnet 3 High Word Of Position (Read Only)
102	Channel B, Magnet 3 Low Word Of Position (Read Only)
103	Channel B, Magnet 4 High Word Of Position (Read Only)
104	Channel B, Magnet 4 Low Word Of Position (Read Only)
105	Channel B, Magnet 5 High Word Of Position (Read Only)
106	Channel B, Magnet 5 Low Word Of Position (Read Only)
107	Channel B, Magnet 6 High Word Of Position (Read Only)
108	Channel B, Magnet 6 Low Word Of Position (Read Only)
109	Channel B, Magnet 7 High Word Of Position (Read Only)
110	Channel B, Magnet 7 Low Word Of Position (Read Only)
111	Channel B, Magnet 8 High Word Of Position (Read Only)
112	Channel B, Magnet 8 Low Word Of Position (Read Only)
113	Channel B, Magnet 9 High Word Of Position (Read Only)
114	Channel B, Magnet 9 Low Word Of Position (Read Only)
115	Channel B, Magnet 10 High Word Of Position (Read Only)
116	Channel B, Magnet 10 Low Word Of Position (Read Only)
117	Channel B, Magnet 11 High Word Of Position (Read Only)
118	Channel B, Magnet 11 Low Word Of Position (Read Only)
119	Channel B, Magnet 12 High Word Of Position (Read Only)
120	Channel B, Magnet 12 Low Word Of Position (Read Only)
121	Channel B, Magnet 13 High Word Of Position (Read Only)
122	Channel B, Magnet 13 Low Word Of Position (Read Only)
123	Channel B, Magnet 14 High Word Of Position (Read Only)
124	Channel B, Magnet 14 Low Word Of Position (Read Only)
125	Channel B, Magnet 15 High Word Of Position (Read Only)
126	Channel B, Magnet 15 Low Word Of Position (Read Only)
127	Channel B, Magnet 16 High Word Of Position (Read Only)
128	Channel B, Magnet 16 Low Word Of Position (Read Only)

Writeable Coils Supported

3	State of Discrete Output 1
4	State of Discrete Output 2

- 5 State of Discrete Output 3
- 6 State of Discrete Output 4
- 7 State of Discrete Output 5
- 8 State of Discrete Output 6

Writeable Registers Supported

- 1 Channel A, Number of magnets expected (Start/Stop only)
- 2 Channel B, Number of magnets expected (Start/Stop only)

MODBUS command details

Note: In the following, [CR] refers to a Carriage Return/Line Feed Pair.

The following commands are shown in ASCII format. For more information on RTU mode, please see the *Modbus Protocol Reference Guide* (available at www.modbus.org).

Read Coil Status

“:XX0100YY00ZZCS[CR]”

Where: **XX** is the hexadecimal slave ID of the desired board
YY is the hexadecimal starting address (first coil)
ZZ is the hexadecimal number of coils to read
CS is the hexadecimal twos complement checksum (LRC)

Requests the status of a set of coils.

Returns: “:XX01BBZZ₀...ZZ_xCS[CR]”

Where: **XX** is the hexadecimal slave ID of the desired board
BB is the data byte count
ZZ₀ through **ZZ_x** are the returned coil values. Coils are returned 1 bit per coil. The first coil requested is the LSB of the first data byte. If the number of coils is not a multiple of 8, the remainder of the byte is padded with 0s.
CS is the hexadecimal twos complement checksum (LRC)

Read Discrete Inputs

“:XX0200YY00ZZCS[CR]”

Where: **XX** is the hexadecimal slave ID of the desired board
YY is the hexadecimal starting address (first register)
ZZ is the hexadecimal number of registers to read
CS is the hexadecimal twos complement checksum (LRC)

Requests the binary contents of a set of discrete inputs

Returns: “:XX02BBZZ₀...ZZ_xCS[CR]”

Where: **XX** is the hexadecimal slave ID of the desired board+
BB is the data byte count
ZZ₀ through **ZZ_x** are the returned input coil values. Coils are returned 1 bit per coil. The first coil requested is the LSB of the first data byte. If the number of coils is not a multiple of 8, the remainder of the byte is padded with 0s.
CS is the hexadecimal twos complement checksum (LRC)

Read Holding Registers

“:XX0300YY00ZZCS[CR]”

Where: **XX** is the hexadecimal slave ID of the desired board
YY is the hexadecimal starting address (first register)
ZZ is the hexadecimal number of registers to read
CS is the hexadecimal twos complement checksum (LRC)

Requests the binary contents of a set of registers

Returns: “:XX03BBZZ₀...ZZ_xCS[CR]”

Where: **XX** is the hexadecimal slave ID of the desired board
BB is the data byte count
ZZ₀ through **ZZ_x** are the returned register values. Registers are returned as two bytes, MSB first.
CS is the hexadecimal twos complement checksum (LRC)

Force Single Coil

“:XX0500YYZZ00CS[CR]”

Where: **XX** is the hexadecimal slave ID of the desired board

YY is the hexadecimal address of the coil

ZZ is set to FF to force the coil ON; 00 to force the coil OFF.

CS is the hexadecimal twos complement checksum (LRC)

Forces (sets) a single coil to either ON or OFF.

Returns: An echo of the query.

Preset Registers

“:XX0600YYZZ₀ZZ₁CS[CR]”

Where: **XX** is the hexadecimal slave ID of the desired board

YY is the hexadecimal address

ZZ₀ Hi byte of the value

ZZ₁ Low byte of the value. Registers are set as two bytes, MSB first.

CS is the hexadecimal twos complement checksum (LRC)

Writes the binary contents of a set of registers

Returns: “:XX03BBZZ₀ZZ₁CS[CR]”

Where: **XX** is the hexadecimal slave ID of the desired board

YY is the hexadecimal addressing

ZZ₀ Hi byte of the value

ZZ₁ Low byte of the value. Registers are set as two bytes, MSB first.

CS is the hexadecimal twos complement checksum (LRC)

Setup

The SAB-S-MODBUS board ships from the factory with default values installed. The default setup is as follows:

ChA expected Magnets: 1
ChB expected Magnets: 1

The number of expected magnets is written using the preset holding registers command for registers 1 and 2. The values of these registers (1 and 2) are stored in EEPROM when written and will remain after the power is cycled. The number of magnets setting is only valid when using a Start/Stop sensor; PWM sensor support is limited to one magnet only. Other values are set via the dipswitches. The following items can be changed:

Baud Rate (8 bits, No Parity, 1 Stop bit)

Switches 1 and 2 define the baud rate.

Baud Rate	Switch 1	Switch 2
2400 bps	OFF	OFF
9600 bps	ON	OFF
19200 bps	OFF	ON
57600 bps	ON	ON

Protocol Mode

Switch 3 selects between ASCII and RTU protocol modes.

Protocol Mode	Switch 3
ASCII	OFF
RTU	ON

Offline Test Mode

Switch 4 activates the Offline Test mode when it is on. See Offline Test Mode section.

Slave ID

Switches 5-8 select the Slave ID of the SAB-S-MODBUS.

Slave ID	Switch 5	Switch 6	Switch 7	Switch 8
1	OFF	OFF	OFF	OFF
2	ON	OFF	OFF	OFF
3	OFF	ON	OFF	OFF
4	ON	ON	OFF	OFF
5	OFF	OFF	ON	OFF
6	ON	OFF	ON	OFF
7	OFF	ON	ON	OFF
8	ON	ON	ON	OFF
9	OFF	OFF	OFF	ON
10	ON	OFF	OFF	ON
11	OFF	ON	OFF	ON
12	ON	ON	OFF	ON
13	OFF	OFF	ON	ON
14	ON	OFF	ON	ON
15	OFF	ON	ON	ON
16	ON	ON	ON	ON

Offline Test mode

If dipswitch 4 is ON when power is applied the SAB-S-MODBUS board enters the Offline Test mode of operation. This mode can be used to see the magnet count for each channel. Connect the board to a serial terminal or PC with terminal emulator software. When the board enters the Offline Test mode the current magnet positions will be printed.

During Offline Test mode, the number of expected magnets can be changed. Send the number zero ('0') to change the number of magnets expected for channel A. Send the number one ('1') to change the number of magnets expected for channel B.

User Configurable Jumpers

Jumper X1 1-3

This jumper selects the serial communications receive format.

X1 1-2 RS485

X1 2-3 RS232

Jumper X1 4-6

This jumper selects the sense of the DC input 1. Install 4-5 for active low input, 5-6 for active high input.

Jumper X1 7-9

This jumper selects the sense of the DC input 2. Install 7-8 for active low input, 8-9 for active high input.

Jumper X2

This jumper connects RS485 line termination resistors. Install 9-10 and 11-12 for the last board in a series of RS485 configured boards to provide 120 Ohm line termination and 1k Ohm biasing resistors.

Jumper X3-5

These jumpers are factory set. Models supporting Start/Stop and PWM sensors have X3 & X5 set 1-2 & 3-5. X4 and X6 set 1-2. Models supporting SSI sensors have X3 & X5 set 1-2. X4 and X6 set to 2-3.

Connectors

Connector JP1

J1 – 1	Logic Ground
J1 – 2	RS232 Receive from host
J1 – 3	RS232 Transmit to host
J1 – 4	RS485 - (RS485-A)
J1 – 5	RS485 +(RS485-B)
J1 – 6	DC input 1. An open-collector output or 5 volt logic can be used to pull this line low.
J1 – 7	DC input 2. An open-collector output or 5 volt logic can be used to pull this line low.
J1 – 8	Status common for channel A and channel B relay outputs.
J1 – 9	Channel A transducer status normally open relay contact. Closed and connected to J1-8 when a good transducer is connected.
J1 – 10	Channel B transducer status normally open relay contact. Closed and connected to J1-8 when a good transducer is connected.

Connector JP2

All signals are 5V TTL level with 20 ma current limit. Each output is available in it's true and complemented form.

J2 – 1	Discrete output 1
J2 – 2	Discrete output 1#
J2 – 3	Discrete output 2
J2 – 4	Discrete output 2#
J2 – 5	Discrete output 3
J2 – 6	Discrete output 3#
J2 – 7	Logic ground
J2 – 8	Discrete output 4
J2 – 9	Discrete output 4#
J2 – 10	Discrete output 5
J2 – 11	Discrete output 5#
J2 – 12	Discrete output 6
J2 – 13	Discrete output 6#
J2 – 14	Logic ground

Connector JP3

Transducer connector

J3 – 1	ChA Interrogate + to the transducer	(YELLOW)
J3 – 2	ChA Interrogate - to the transducer	(GREEN)
J3 – 3	ChA Gate + from the transducer	(PINK)
J3 – 4	ChA Gate - from the transducer	(GRAY)
J3 – 5	+ Power to the transducer	(RED)
J3 – 6	Ground	(WHITE & SHIELD)
J3 – 7	- Power to the transducer	(BLUE)
J3 – 8	ChB Interrogate + to the transducer	(YELLOW)
J3 – 9	ChB Interrogate - to the transducer	(GREEN)
J3 – 10	ChB Gate + from the transducer	(PINK)
J3 – 11	ChB Gate - from the transducer	(GRAY)
J3 – 12	+ Power to the transducer	(RED)
J3 – 13	Ground	(WHITE & SHIELD)
J3 – 14	- Power to the transducer	(BLUE)

Connector JP4

The board is powered via J4; the board can operate on any DC voltage from 7.5V to 26VDC. However, the voltage input on J4-1 is also passed along to the transducers via J3-5 and J3-12. When using transducers requiring +24V apply +24V to J4-1, ground to J4-2 and do not apply any voltage at J4-3. For transducers requiring +/- 15V apply +15V to J4-1, ground J4-2 and apply -15V to J4-3.

J4 – 1	+7.5 to +26 VDC input the board and the transducers (typically +24VDC)
J4 – 2	Power supply and signal ground
J4 – 3	-15 VDC input to the board (for sensors requiring -15V only)

Power Consumption

The board consumes approximately 100 milliamps of the + input voltage supplied to J4-1 for its own operation. Each transducer attached requires approximately 100 milliamps of the + input voltage for a total of 300 milliamps. The board does not require the – input voltage at J4-3 but passes it along to the transducer.

Connections

The board and the connectors are oriented as shown here. There is a direct connection from J4-1 to J3-5 and 12. There is also a direct connection from J4-3 to J3-7 and 14. Ground is common to J4-2, J3-6, J3-13, J2-7, J2-14 and J1-1.

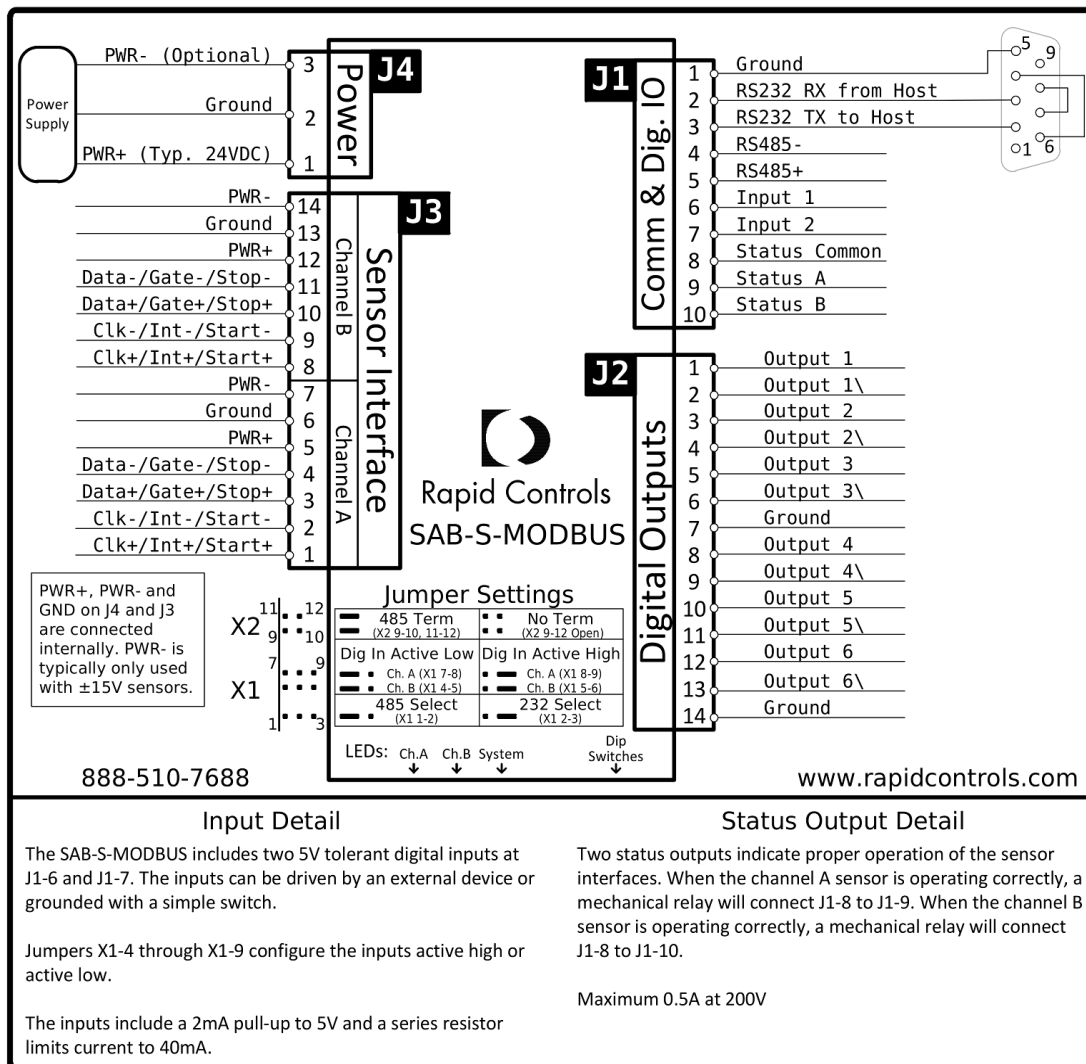

Input Detail

The SAB-S-MODBUS includes two 5V tolerant digital inputs at J1-6 and J1-7. The inputs can be driven by an external device or grounded with a simple switch.

Jumpers X1-4 through X1-9 configure the inputs active high or active low.

The inputs include a 2mA pull-up to 5V and a series resistor limits current to 40mA.

Status Output Detail

Two status outputs indicate proper operation of the sensor interfaces. When the channel A sensor is operating correctly, a mechanical relay will connect J1-8 to J1-9. When the channel B sensor is operating correctly, a mechanical relay will connect J1-8 to J1-10.

Maximum 0.5A at 200V

Enclosure

The SAB-S-MODBUS comes mounted in a DIN rail enclosure, containing one or two SAB-S-MODBUS boards. The enclosure is 4.64 inches deep x 5.31 deep x 1.77 wide, and uses 1.8 inches or DIN rail space.

This configuration can provide up to four channels of magnetostrictive transducer input per enclosure.

